

CURTISS - WRIGHT

Tritex II® Series Actuators 75 mm Actuator

INSTALLATION AND SERVICE MANUAL

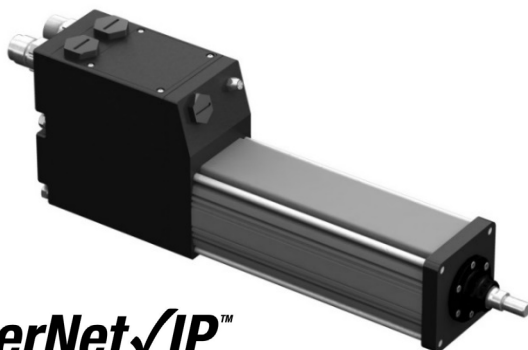

EtherNet/IP™
conformance tested



EXLAR®

Curtiss-Wright
18400 West 77th Street
Chanhassen, MN 55317

Phone: 855-620-6200 (US & Canada)

Phone: 952-500-6200

Fax: 952-368-4877

Website: www.cw-actuation.com

Tritex II® Series Actuators



EtherNet/IP™
conformance tested



240VAC Linear and Rotary Actuator 75 mm Frame Size Installation and Service Manual

Information furnished by Exlar Corporation is believed to be accurate and reliable. However, no responsibility is assumed by Exlar Corporation for its use. Exlar reserves the right to change the design and operation of the equipment described herein and any associated motion products that may appear in this document. Information in this document pertaining to equipment not furnished by Exlar should be confirmed by that equipment manufacturer. Exlar assumes no responsibility for changes to information by other manufacturers or errors in that information or the description of that information. Information in this document is subject to change without notice.

This document does not contain any export controlled technical data.

WARRANTY AND LIMITATION OF LIABILITY

Please see our warranty on our website here: [Division Policies | About | Actuation Division | Curtiss-Wright Actuation Group \(cw-actuation.com\)](#) for details.

TABLE OF CONTENTS

Safety Considerations	5
<i>Warnings and Cautions</i>	5
<i>Underwriters Laboratories UL Recognized</i>	8
<i>UL Certificate of Compliance</i>	9
<i>CE Declaration of Conformity</i>	11
<i>UK Declaration of Conformity</i>	11
<i>EU Declaration of Conformity</i>	11
<i>CSA Certified Product</i>	16
General Specifications	19
<i>Tritex II Overview</i>	19
<i>Drive Specification for all Tritex 240 Volt Models</i>	20
<i>Actuator Selections</i>	21
<i>Linear Actuator Ordering Guide</i>	22
<i>Rotary Motor and Gearmotor Ordering Guide</i>	22
Mechanical Installation	24
<i>Mounting and Operating Considerations</i>	24
<i>Lubrication</i>	24
<i>General Operation</i>	25
<i>Mounting Configurations</i>	25
<i>T2M Series Linear Actuator Anti-rotation Option</i>	25
<i>Outdoor and Wash Down Installations</i>	26
<i>Manual Drive Operating Instructions</i>	27
Electrical Installation	29
<i>Introduction</i>	29
<i>Cable Entry</i>	30
<i>Grounding</i>	32
<i>Shielding</i>	33
<i>AC Input Power</i>	34
Input Power Ratings	34
AC Supplies NOT Requiring Transformers	34
AC Supplies Requiring Transformers	37
Single Phase Isolation Transformer connections	38
Wire Size, Branch Circuit Protection and Overcurrent Protection ...	39
Power Terminal Wiring	39
Power Connector Wiring	41
<i>Over Temperature Protection</i>	41
<i>Brake / Shunt Resistor Considerations</i>	42

<i>Logic and IO Power Supply</i>	44
Tritex Input and Output Wiring	46
Input/Output Connections.....	47
Digital Inputs.....	49
Digital Outputs.....	50
Actuator Brake Option	51
Analog Input	53
Analog Output.....	54
Communications.....	54
PC Communications.....	56
IA4 Option board connections.....	57
AF Option, Absolute Feedback	60
Ethernet Options, EIP, TCP or ProfiNet IO	61
CANopen	63
Maintenance Procedures for Re-Greasing	65
<i>Maintenance Procedure for Roller Screw Re-Greasing</i>	65
Disassembly	65
Lubrication Maintenance	66
Grease Renewal.....	67
Reassembly.....	67
<i>Maintenance Procedures for Complete Re-Greasing</i>	68
Disassembly	68
Lubrication Maintenance	69
Grease Renewal.....	69
Reassembly.....	70
Accessories	72
<i>Cables</i>	72
TTIOC-xxx I/O Cable	72
TTICO-xxx Communications Cable.....	74
<i>Communication Converter</i>	75
<i>Braking Resistor T2BR1</i>	76
Returning a Product for Repair	77

SAFETY CONSIDERATIONS

Warnings and Cautions

As with any electro-mechanical device, safety must be considered during the installation and operation of your Tritex Series actuator. Throughout this manual you will see paragraphs marked with CAUTION and WARNING signs as shown below:

WARNING



“**WARNING**” indicates the information following is essential to avoiding a safety hazard.

CAUTION



“**CAUTION**” indicates the information following is necessary for avoiding a risk of damage to the product or other equipment.

WARNING



General

Failure to follow safe installation guidelines can cause death or serious injury. The voltages used in the product can cause severe electric shock and/or burns and could be lethal. Extreme care is necessary at all times when working with or adjacent to the product. The installation must comply with all relevant safety legislation in the country of use. The forces created by actuator could be lethal or cause severe injury if proper protection is not provided to keep personnel away from moving components.

WARNING



System Design and safety for personnel

The actuator is intended as a component for professional incorporation into complete equipment or a system. If installed incorrectly, the actuator may present a safety hazard. The actuator uses high voltages and currents, carries a high level of stored electrical energy, and is used to control equipment which can cause injury. Close attention is required to the electrical installation and the system design to avoid hazards either in normal operation or in the event

of equipment malfunction. System design, installation, commissioning and maintenance must be carried out by personnel who have the necessary training and experience. They must read this safety information and this manual carefully.

None of the functions or features of the Tritex actuator may be used to ensure safety of personnel, i.e. they must not be used for safety-related functions.

For example, the actuators enable / disable, brake, stop/start and forward/reverse functions are not sufficient for use in safety-critical applications without additional independent channels of protection. Careful consideration must be given to the functions of the actuator which might result in a hazard, either through their intended behavior or through incorrect operation due to a fault. In any application where a malfunction of the actuator or its control system could lead to or allow damage, loss or injury, a risk analysis must be carried out, and where necessary, further measures taken to reduce the risk.- for example a failsafe brake in case of loss of actuator braking power.

WARNING



Never attempt to connect or disconnect the actuator with power applied.

Dangerous voltages are present. Damage to equipment and injury to personnel can result. Refer to the following warnings on supply isolation and stored energy discharge time for more information.

WARNING



Supply isolation

The AC supply or high voltage DC supply must be removed from the actuator using an approved isolation device or disconnect before any maintenance is performed except adjustments to the settings or parameters as specified in the manual.

WARNING



**Risk of Electric Shock
Allow 3 minutes for Discharge Time**

3-Minutes

The actuator contains capacitors that remain charged to a potentially lethal voltage for up to 3 minutes after the supply has been removed. Do not remove cable or cover or touch power wiring terminals until this discharge time has expired.

WARNING



If connected by plug and socket

A special hazard may exist where the actuator is incorporated into a system connected to the AC supply by a plug and socket. The pins of the plug are not generally isolated from the charge stored in the bus capacitor, so must be considered electrically “hot” until the discharge time has expired. It is the responsibility of the user to avoid any possibility of electric shock from the pins when they are accessible.

WARNING



Grounding - High Leakage Current

The drive must be grounded by a conductor sufficient to carry all possible fault current in the event of a fault. This equipment has high earth leakage current. You must comply with local safety regulations with respect to minimum size and special installation requirements on the protective earth conductor for high leakage current equipment. The instructions for ground connections shown in this manual must be followed.

CAUTION



Compatibility with Residual Current-operated Protection Device (RCD)

This product can cause a DC current in the protective earthing conductor. Where a residual current –operated protective (RCD) or monitoring (RCM) device is used for protection in case of direct or indirect contact, only an RCD or RCM of Type B is allowed on the supply side of this product.

WARNING



Hot Surface – Risk of Burn

Exposed surfaces of the actuator may exceed 70°C under normal operation and can take a long time to cool, resulting in a risk of burns when touched.

Underwriters Laboratories UL Recognized



UL Recognized
UL File E353255

Tritex II 75 mm Linear and Rotary Actuators are marked “UL Recognized” after passing a rigorous set of design and testing criteria developed by Underwriters Laboratories UL 508C, UL 1004-1, UL 1004-3 and UL 1004 -7. This UL logo indicates that UL certifies this product to be safe when installed according to the installation instructions and used in accordance with the product specifications and the following conditions of acceptability:

The conditions of acceptability required by UL are:

- Drive input maximum continuous operating ratings:

Input Voltage (all models): 240 VAC, 1 Φ, 50/60 Hz		
Drive/Motor Model	Stator	Input Continuous Current (Arms)
T2M/R2M/R2G 075	1 Stack Stator	4.3
T2M/R2M/R2G 075	2 Stack Stator	4.0
T2M/R2M/R2G 075	3 Stack Stator	3.6

- Above full load ratings are at a maximum surrounding air temperature of 40°C.
- Suitable for use on a circuit capable of delivering not more than 10,000 rms symmetrical amperes, 240 Volts maximum when protected by Class CC or Class RK1 fuses, or when protected by a circuit breaker having an interrupting rating.
- Integral solid state short circuit protection does not provide branch circuit protection. Branch circuit protection must be provided in accordance with the National Electrical Code and any additional local codes.
- Use 14 AWG wire with insulation rated for 105°C input power and PE terminals.
- Multiple connection options covered in the model mask nomenclature in the report.

CERTIFICATE OF COMPLIANCE

Certificate Number 20141011-E353255
Report Reference E353255-20140828
Issue Date 2014-OCTOBER-11

Issued to: EXLAR CORP
18400 W 77TH ST
CHANHASSEN MN 55317-9257

This is to certify that representative samples of COMPONENT - ELECTRONICALLY PROTECTED MOTORS WITH INTEGRAL CONTROLLERS FOR INDUSTRIAL USE
See Addendum.

Have been investigated by UL in accordance with the Standard(s) indicated on this Certificate.

Standard(s) for Safety: Standard for Rotating Electrical Machines – General Requirements, UL 1004-1.
Standard for Thermally Protected Motors, UL 1004-3.
Standard for Electronically Protected Motors, UL 1004-7.

Additional Information: See the UL Online Certifications Directory at www.ul.com/database for additional information

Only those products bearing the UL Recognized Component Mark should be considered as being covered by UL's Recognition and Follow-Up Service.

The UL Recognized Component Mark generally consists of the manufacturer's identification and catalog number, model number or other product designation as specified under "Marking" for the particular Recognition as published in the appropriate UL Directory. As a supplementary means of identifying products that have been produced under UL's Component Recognition Program, UL's Recognized Component Mark: , may be used in conjunction with the required Recognized Marks. The Recognized Component Mark is required when specified in the UL Directory preceding the recognitions or under "Markings" for the individual recognitions.

Recognized components are incomplete in certain constructional features or restricted in performance capabilities and are intended for use as components of complete equipment submitted for investigation rather than for direct separate installation in the field. The final acceptance of the component is dependent upon its installation and use in complete equipment submitted to UL LLC.

Look for the UL Recognized Component Mark on the product.



William R. Carney, Director, North American Certification Programs
UL LLC

Any information and documentation involving UL Mark services are provided on behalf of UL LLC (UL) or any authorized licensee of UL. For questions, please contact a local UL Customer Service Representative at www.ul.com/contactus



CERTIFICATE OF COMPLIANCE

Certificate Number 20141011-E353255
Report Reference E353255-20140828
Issue Date 2014-OCTOBER-11

This is to certify that representative samples of the product as specified on this certificate were tested according to the current UL requirements.

Motors, Models T2M075-xxxx-xxx-xx-138-40-230-xxx-xx..xx-xxxxx, T2M075-xxxx-xxx-xx-238-30-230-xxx-xx..xx-xxxxx, T2M075-xxxx-xxx-xx-338-20-230-xxx-xx..xx-xxxxx, T2X075-xxxx-xxx-xx-138-40-230-xxx-xx..xx-xxxxx, T2X075-xxxx-xxx-xx-238-30-230-xxx-xx..xx-xxxxx, T2X075-xxxx-xxx-xx-338-20-230-xxx-xx..xx-xxxxx, R2M075-xxxx-xxx-138-40-230-xxx-xx..xx-xxxxx, R2M075-xxxx-xxx-238-30-230-xxx-xx..xx-xxxxx, R2M075-xxxx-xxx-338-20-230-xxx-xx..xx-xxxxx, R2G075-xxxx-xxx-138-40-230-xxx-xx..xx-xxxxx, R2G075-xxxx-xxx-238-30-230-xxx-xx..xx-xxxxx, R2G075-xxxx-xxx-138-30-230-xxx-xx..xx-xxxxx, R2G075-xxx-xxxx-xx-338-20-230-xxx-xx..xx-xxxxx.



William R. Carney, Director, North American Certification Programs
UL LLC

Any information and documentation involving UL Mark services are provided on behalf of UL LLC (UL) or any authorized licensee of UL. For questions, please contact a local UL Customer Service Representative at www.ul.com/contactus





The Tritex II 75 mm Linear and Rotary Actuators are marked with the “Conformité Européenne Mark” (CE Mark) after passing a rigorous set of design and testing criteria. This label indicates the product meets applicable electrical safety, and electromagnetic immunity and emissions (EMC) standards when installed according to the installation instructions.

The conditions of acceptability required for CE are:

- Drive input maximum continuous operating ratings:

Input Voltage (all models): 240 VAC, 1 Φ, 50/60 Hz		
Drive/Motor Model	Stator	Input Continuous Current (Arms)
T2M/R2M/R2G 075	1 Stack Stator	4.3
T2M/R2M/R2G 075	2 Stack Stator	4.0
T2M/R2M/R2G 075	3 Stack Stator	3.6

- Above full load ratings are at a maximum surrounding air temperature of 40°C.
- Field installation power connection wires: Use 2.5mm², 300 VAC minimum rating, and 105° C minimum rating copper wires.
- Two externally connected ground wires must be used and connected to protective earth ground (PE). Note: two PE connection terminals are provided since touch is greater than 3.5mA. This wire is required to be no less 2.5mm² since mechanical protection of is provided via hard conduit or a cable assembly.
- This product is suitable for use on a circuit capable of delivering up to 10,000 rms symmetrical amperes, 240 volts maximum, when protected with by a Class RK1 or Class CC fuse or Inverse Time Circuit Breaker, rated at 15 Arms.
- All cables must be shielded, with the outer shield bonded to the case.
- When using cable glands use glands that connect the braided shield of the cable directly to enclosure.
- When using connectors ensure that the outer shield of the cable is in full contact with the connector housing. Connector housings must conductive.

- Make ground connections as short as possible for low impedance.
- Keep cable runs as short as possible. Power and signal cables must be separated and far as possible and only crossing them at right angles as described in the Cable routing section of this manual.
- IP 66 rating:
- To maintain IP ratings, the RS485 cable or cap must be installed. All other cable connections must be connected or sealed.

UK Declaration of Conformity

This declaration is issued under the sole responsibility of the manufacturer.

*The undersigned, representing the
Manufacturer*

*Exlar Corporation
18400 West 77th Street
Chanhassen, MN 55317 USA*

*Declares, that the Exlar Brand Products:
T2M, T2X, R2M and R2G Linear and Rotary Actuators*

Complete Model identification:

*T2M090, T2M115, T2X090, T2X115,
R2M090, R2M115, R2G090, R2G115,
T2M075, T2X075, R2M075, R2G075*

*The objects of the declaration described above is in conformity with the
relevant UK Statutory Instrument (and their amendments):*

Per directives listed below:

<i>2016 No. 1091</i>	<i>Electromagnetic Compatibility Regulations (EMC)</i>
<i>2016 No. 1101</i>	<i>Electrical Equipment (Safety) Regulations (LV)</i>
<i>2012 No. 3032</i>	<i>The Restriction of the Use of Hazardous Substances in Electrical and Electronic Equipment Regulations (RoHS)</i>

*Using the relevant section of the following Harmonized standards and other
normative documents:*

*EMC: EN 61800-3:2004+A1:2012 Adjustable Speed Electrical Power
Drive Systems – Part 3: EMC Requirements and Specific Test
Methods*

*Safety: EN 61800-5-1:2007 Adjustable Speed Electrical
Power Drive Systems -Part 5-1: Safety Requirements*

Signature:



*Name: Robert Schulz
Position: Sr. Engineering Manager
Date of Issue: June 13, 2022*

EU Declaration of Conformity

This declaration is issued under the sole responsibility of the manufacturer.

*The undersigned, representing the
Manufacturer
Exlar Corporation
18400 West 77th Street
Chanhassen, MN 55317 USA*

*Declares, that the Exlar Brand Products:
T2M, T2X, R2M and R2G Linear and Rotary Actuators*

*(Complete Model Listing Below)
Model identification:
T2M090, T2M115, T2X090, T2X115,
R2M090, R2M115, R2G090, R2G115,
T2M075, T2X075, R2M075, R2G075*

*The objects of the declaration described above is in conformity with the
relevant European Union harmonization legislation.*

Per directives listed below:

*EU EMC Directive 2014/30/EU
EU Low Voltage Directive 2014/35/EU
RoHS Directive (2011/65/EU, as amended by (EU) 2015/863)*

*Using the relevant section of the following Harmonized standards and other
normative documents:*

*EMC: EN 61800-3:2004+A1:2012 Adjustable Speed Electrical Power Drive Systems
– Part 3: EMC Requirements and Specific Test Methods*

*Safety: EN 61800-5-1:2007 Adjustable Speed Electrical Power Drive
Systems -Part 5-1: Safety Requirements*

Signature: 

*Name: Robert Schulz
Position: Sr. Engineering Manager
Date of Issue: May 3, 2022*

Per EU directives implemented on April 20th, 2016 the following requirement for requirement must be followed by Importers and Distributors.

The requirements for importers include:

Importers shall indicate their name, registered trade name or registered trade mark and the postal address at which they can be contacted on the apparatus (unless that is not possible, in which case it should be included on the packaging or in an accompanying document).

Importers shall ensure that the product is accompanied by instructions and safety information in a language which can be easily understood by end-users, as determined by the Member State concerned.

Importer is to translate the EU declaration of conformity into the languages required by the member state(s), where the product is sold." Importers shall keep a copy of the EU declaration of conformity (for 10 years).

Importers shall provide a reasoned request from a competent national authority and provide it with all the information and documentation in paper or electronic form necessary to demonstrate the conformity of a product in a language which can be easily understood by that authority.

Importers shall ensure that, while apparatus is under their responsibility, its storage or transport conditions do not jeopardize its compliance with the safety objectives.

Importer shall corrective action necessary when they consider or have reason to believe that the product is not in conformity with its directive(s).

The requirements for distributor include:

Distributors shall indicate their name, registered trade name or registered trade mark and the postal address at which they can be contacted on the apparatus (unless that is not possible, in which case it should be included on the packaging or in an accompanying document).

Distributor shall ensure that apparatus is accompanied by instructions and safety information in an appropriate language. Distributor shall translate the EU declaration of conformity into the languages required by the member state(s), where the product is sold." Distributors shall keep a copy of the EU declaration of conformity (for 10 years).

Distributor shall ensure that, while apparatus is under their responsibility, its storage or transport conditions do not jeopardize its compliance with the safety objectives.

Distributor shall corrective action necessary when they consider or have reason to believe that the product is not in conformity with its directive(s).



The Tritex II 75 mm Linear and Rotary Actuators are marked as shown after passing a rigorous set of design and testing criteria developed by CSA International (C22.2 No. 139) and Underwriters Laboratories (UL 429). This label indicates that CSA certifies this product to be safe when installed according to the installation guidelines and used with the scope of the product specifications.

The conditions of acceptability required by CSA are:

- Drive input maximum continuous operating ratings

Input Voltage (all models): 240 VAC, 1 Φ, 50/60 Hz			
Drive/Motor Model	Stator	Input Continuous Current (Arms)	Torque Rating max.
T2M/R2M/R2G 075	1 Stack Stator	4.3	12.0 lbf-in
T2M/R2M/R2G 075	2 Stack Stator	4.0	22.0 lbf-in
T2M/R2M/R2G 075	3 Stack Stator	3.6	30.0 lbf-in

- Installation Requirements
 - Hazardous Location (Class I Division 2 Group A, B, C, D) installations – ½” rigid conduit with NPT connections and use UL approved copper only wires, 14 AWG, 300 VAC minimum rating, and 105° C minimum rating shall be used.
 - For other non-hazardous locations:
 - Use the above connection method, or
 - Cable with connector assemblies, or
 - Cables with cable glands are permitted.

For additional information on cable installations or part numbers contact Exlar Corporation.

- Branch circuit protection must be provided. Reference the manual’s electrical installation section for fuse and circuit breaker options. Note: branch circuit protection must be located outside of the hazardous location environment,
- The full load ratings are at 40°C ambient temperature and ratings are derated linearly from 40°C to 65°C.
- These conditions of acceptability only apply to units with a CSA mark on the product label.



Certificate of Compliance

Certificate: 70030548

Master Contract: 163694

Project: 70030548

Date Issued: June 19, 2015

Issued to: Exlar Corporation
18400 West 77th St
Chanhassen, MN 55317
USA
Attention: Bill Zerull

The products listed below are eligible to bear the CSA Mark shown with adjacent indicators 'C' and 'US' for Canada and US or with adjacent indicator 'US' for US only or without either indicator for Canada only.



Jay McVeigh

Issued by: Jay McVeigh

PRODUCTS

- CLASS 3221 02** - VALVES - General purpose Actuators
- CLASS 3221 82** - VALVES - Actuators - Certified to US Standards
- CLASS 3228 02** - VALVES - Actuators - For Hazardous Locations
- CLASS 3228 82** - VALVES - Actuators - For Hazardous Locations-Certified to U.S. Standard

CLASS 3221 02 - VALVES - Actuators

CLASS 3221 82 - VALVES - Actuators - CERTIFIED TO U.S. STANDARDS

- Tritex T2M & T2X 75mm Series Linear Actuators and R2M & R2G 75mm Series Rotary

Actuators, input rated 100 – 240VAC, 4.3A max., 30.0 lbf-in max., $-40^{\circ}\text{C} \leq T_a \leq +65^{\circ}\text{C}$; 0.5 seconds typical extension and 0.5 seconds typical retraction, continuous duty

Note: Derate input current linearly above $T_a = 40\text{C}$ to 3.0A max. at 65C.



Certificate: 70030548

Master Contract: 163694

Project: 70030548

Date Issued: June 19, 2015

CLASS 3228 02 - VALVES - Actuators - For Hazardous Locations

CLASS 3228 82 - VALVES - Actuators - For Hazardous Locations - CERTIFIED TO U.S. STANDARDS

CSA Class I, Division 2, Group A, B, C and D Certification Ratings:

- Tritex T2M & T2X 75mm Series Linear Actuators and R2M & R2G 75mm Series Rotary Actuators, input rated 100 – 240VAC, 4.3A max., 30.0 lbf-in max., $-40^{\circ}\text{C} \leq T_a \leq +65^{\circ}$; T3; 0.5 seconds typical extension and 0.5 seconds typical retraction, continuous duty
Note: Derate input current linearly above $T_a = 40\text{C}$ to 3.0A max. at 65C.

Notes:

1. The actuators may include a holding brake. The thermal effects of the brake pad have not been evaluated and are to be considered by the authority having jurisdiction.
2. I/O terminals must be connected to Class 2 circuits when in use.

APPLICABLE REQUIREMENTS

CSA C22.2 No 0 - 10 - General Requirements - Canadian Electrical Code Part II
CSA C22.2 No 0.4 - 04 - Bonding of Electrical Equipment
CSA C22.2 No 139 - 2013 - Electrically Operated Valves
CSA C22.2 No 213 - M1987 (R2013) - Non-Incendive Electrical Equipment for Use in Class I, Division 2 Hazardous Locations
UL 429 - 7th Ed - Electrically Operated Valves
ISA 12.12.01: 2013 - Nonincendive Electrical Equipment for Use in Class I and II, Division 2 and Class III, Divisions 1 and 2 Hazardous (Classified) Locations

General Specifications

Tritex II Overview

Tritex II is Exlar's advanced family of integrated drives. This manual applies to 75 mm frame size only with 240VAC input power. All of the required power components and motion processor are contained in the actuator housing.

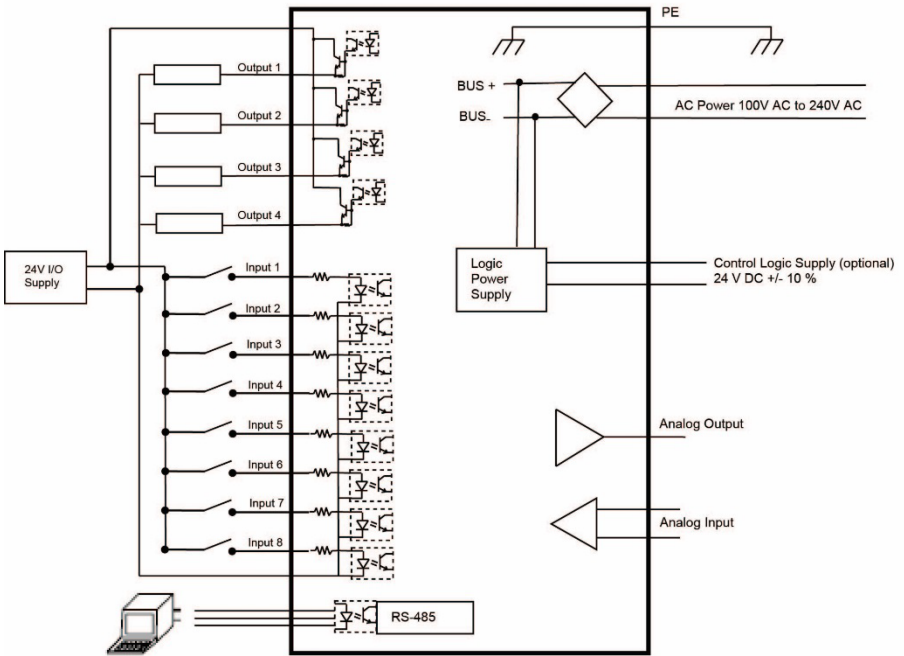

Basic Block Diagram with SIO Option

Drive Specification for all Tritex II -75 mm 240 Volt Models

Drive Specifications	
Input Voltage, Bus and Logic	100 to 240 Volts AC nominal +/-10% overvoltage. Overvoltage Category II, Pollution Degree 2, Required type of electrical supply system is TN.
External Power Supply (Optional)	24 V dc +/- 10% - Provides power for IO, Brake and Logic, Class 2 or isolating source protected by 3A maximum fuse 0.5 A dc max load
Enclosure Rating	IP:66
Digital Inputs	SIO & Ethernet options: 8 – opto isolated, IA4 or CAN option 4- opto isolated 12 to 30 Vdc for ON state, 0 to 1V dc for OFF state, common return at “I/O Power Supply” “common” terminal Programmable functions
Digital Outputs	SIO & Ethernet options: 4 – opto isolated, IA4 or CAN option 3- opto isolated 100 mA continuous, short circuit protected, powered from “I/O Power Supply” with 1V maximum drop from supply voltage, programmable functions
Analog Input	0-10 Volts or +/- 10 Volts differential input, 13 bit resolution, programmable as position, velocity or torque command
Analog Output	0-10 Volts at up to 10 mA, 11 bit resolution, programmable functions
Serial Interface	Optically isolated RS-485, Modbus RTU protocol, 38.4kbaud max
Commutation	Sinusoidal, 10kHz PWM
Position Resolution	0.001 revolution (with analog hall feedback)
Accuracy	+ / - 0.002 revolution (with analog hall feedback)
Environmental	Ambient Temperature, charts below show ratings for 40° C Maximum Operating temperature range -20° to 65° C See de-rating chart for temperatures above 40° C. For operation below -20°C contact Exlar Applications Engineering. Storage Temperature -40°C to 85°C. Operational Altitude is 2000 meters.

Actuator Selections

This manual applies to 75mm frame size only.

Tritex actuators are available in linear, rotary, and rotary with integrated planetary. All include embedded drive and motion controller.

Frame Size	Linear		Rotary Motor	Rotary Gearmotor
	Std. Capacity	High Capacity		
75 mm	T2M-075	T2X-075	R2M-075	R2G-075

Extended Temperature De-ratings

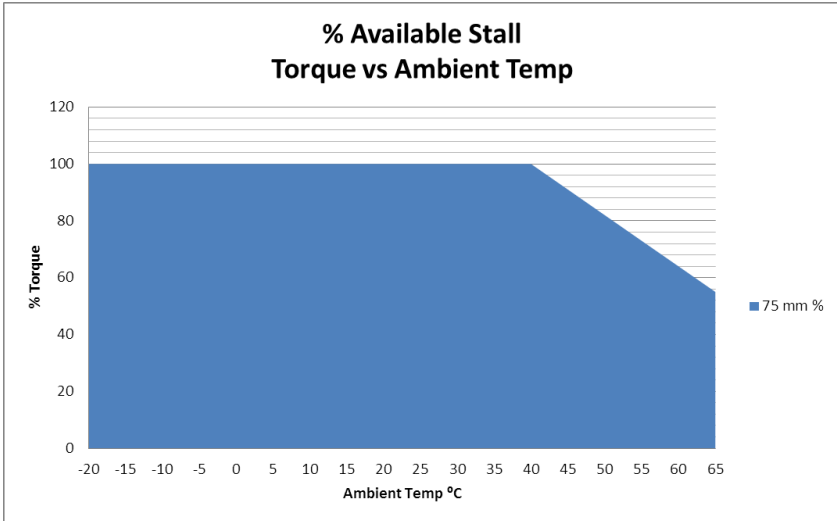

Use this chart to determine continuous (rms) rated torque values at elevated temperatures. Peak torque ratings are not affected.

Linear Actuator Ordering Guide

T2M/X = Actuator Type

T2M = Tritex II Linear Actuator, standard mechanical capacity

T2X = Tritex II Linear Actuator, high mechanical capacity

BBB = Actuator Frame Size

075 = 75 mm

090 = 90 mm

115 = 115 mm

CC = Stroke Length

03 = 3 inch (76 mm) (N/A T2M/X115)

04 = 4 inch (102 mm) (T2M/X115 only)

06 = 6 inch (150 mm)

10 = 10 inch (254 mm)

12 = 12 inch (305 mm)

18 = 18 inch (457 mm)

DD = Screw Lead (linear travel per screw revolution)

01 = 0.1 inch (2.54 mm)

02 = 0.2 inch (5.08 mm)

05 = 0.5 inch (12.7 mm)

08 = 0.75 inch (19.05 mm) (T2M/X115 only) ⁵

E = Connections

G = Standard Straight Threaded Port with Internal terminals, M20 x 1.5

N = NPT Threaded Port via Adapter with Internal Terminals, 1/2" NPT

I = Intercontec Style - Exlar std, M16/M23 Style Connector

J = Embedded leads with "I" plug 3' standard

F = Mounting

C = Rear Clevis

D = Double Side Mount

E = Extended Tie Rod

F = Front Flange

G = Metric Rear Clevis

K = Metric Double Side Mount

M = Metric Extended Tie Rod

Q = Metric Side Trunnion

R = Rear Flange

T = Side Trunnion

G = Rod End

A = Male Metric Thread ¹

B = Female Metric Thread ¹

F = Female US Standard Thread ¹

M = Male US Standard Thread ¹

HH = Feedback Type

HD = Analog Hall Device

IE = Incremental Encoder, 8192 count resolution

AF = Absolute Feedback

III-II = Motor Stator, All 8 Pole

T2M/X075 Stator Specifications

138-40 = 1 Stack, 230 VAC, 4000 rpm

238-30 = 2 Stack, 230 VAC, 3000 rpm

338-20 = 3 Stack, 230 VAC, 2000 rpm

T2M/X090 Stator Specifications

138-40 = 1 Stack, 230 VAC, 4000 rpm

238-40 = 2 Stack, 230 VAC, 4000 rpm

238-30 = 2 Stack, 230 VAC, 3000 rpm ⁹

T2M/X115 Stator Specifications

138-30 = 1 Stack, 230 VAC, 3000 rpm

238-20 = 2 Stack, 230 VAC, 2000 rpm ¹¹

238-15 = 2 Stack, 230 VAC, 1500 rpm ^{9, 11}

(N/A with 0.1" lead)

JJJ = Voltage

230 = 115-230 VAC, single phase

KKK = Option Board

SIO = Standard I/O Interconnect

IA4 = 4-20 mA Analog I/O

COP = CANOpen w/M12 connector

CON = CANOpen, without M12 ¹⁰

EIP = SIO plus Ethernet/IP w/M12 connector

EIN = SIO plus Ethernet/IP without M12 connector ¹⁰

PIO = SIO plus Profinet IO w/M12 connector

PIN = SIO plus Profinet IO without M12 connector ¹⁰

TCP = SIO plus Modbus TCP w/M12 connector

TCN = SIO plus Modbus TCP w/o M12 connector ¹⁰

MM = Mechanical Options ⁶

AR = External Anti-rotate

L1/2/3 = External Limit Switches ⁷

RB = Rear Brake

PB = Protective Bellows (N/A with extended tie rod mounting option)

SR = Splined Main Rod ^{8, 2}

NOTES:

1. Chrome-plated carbon steel. Threads not chrome-plated.
2. Consult Exlar when ordering splined stainless steel main rod.
3. The dynamic load rating of zero backlash, preloaded screws is 63% of the dynamic load rating of the std non-preloaded screws. The calculated travel life of a preloaded screw will be 25% of the calculated travel life of the same size and lead of a non-preloaded screw.
4. This housing option may indicate the need for special material main rods or mounting.
5. 0.75 lead not available above 12 inch stroke.
6. For extended temperature operation consult factory for model number.
7. Limit switch option requires AR option.

8. This option is not sealed and is not suitable for any environment in which contaminants come in contact with actuator and may enter the actuator.
9. N/A with 0.1 inch lead
10. Requires customer supplied Ethernet cable through I/O port for Class 1 Division 2 compliance only.
11. Not available with 4 inch stroke.

Rotary Motor and Gearmotor Ordering Guide

R2M/G = Motor Type

R2M = Tritex II AC Rotary Motor

R2G = Tritex II AC Rotary Gearmotor

AAA = Frame Size

075 = 75 mm

090 = 90 mm

115 = 115 mm

BBB = Gear Ratio

Blank = R2M

Single Reduction Ratios

004 = 4:1

005 = 5:1

010 = 10:1

Double Reduction Ratios (N/A on 75 mm)

016 = 16:1 020 = 20:1

025 = 25:1 040 = 40:1

050 = 50:1 100 = 100:1

C = Shaft Type

K = Keyed

R = Smooth/Round

D = Connections

G = Standard Straight Threaded Port with Internal Terminals, M20 x 1.5

N = NPT Threaded Port with Internal Terminals, 1/2" NPT

I = Intercontec style - Exlar Standard, M16/M23 Style Connector

J = Embedded leads with "I" plug 3' standard

E = Coating Options

G = Exlar Standard

F = Brake Option

S = No Brake, Standard

B = Electric Brake, 24 VDC

GG = Feedback Type

HD = Analog Hall Device

IE = Incremental Encoder, 8192 Count Resolution

AF = Absolute Feedback

HHH-HH = Motor Stators

R2M/G075 Stator Specifications

138-40 = 1 Stack, 230 VAC, 4000 rpm

238-30 = 2 Stack, 230 VAC, 3000 rpm

338-20 = 3 Stack, 230 VAC, 2000 rpm

R2M/G090 Stator Specifications

238-40 = 2 Stack, 230 VAC, 4000 rpm

238-30 = 2 Stack, 230 VAC, 3000 rpm

338-20 = 3 Stack, 230 VAC, 2000 rpm

R2M/G115 Stator Specifications

138-30 = 1 Stack, 230 VAC, 3000 rpm

238-20 = 2 Stack, 230 VAC, 2000 rpm

238-15 = 2 Stack, 230 VAC, 1500 rpm

III = Voltage

230 = 115-230 VAC, Single Phase

JJJ = Option Board

SIO = Standard I/O Interconnect

IA4 = 4-20 mA Analog I/O

COP = CANOpen w/M12 connector

CON = CANOpen, without M12 connector ¹

EIP = SIO plus Ethernet/IP w/M12 connector

EIN = SIO plus Ethernet/IP without M12 connector ¹

PIO = SIO plus Profinet IO w/M12 connector

PIN = SIO plus Profinet IO without M12 connector ¹

TCP = SIO plus Modbus TCP w/M12 connector

TCN = SIO plus Modbus TCP w/o M12 connector ¹

NOTES:

1. Requires customer supplied Ethernet cable through I/O port for Class 1 Division 2 compliance only.
2. For extended temperature operation, consult factory for model number.

Mechanical Installation

Mounting and Operating Considerations

Every effort should be made to minimize misalignment of the output shaft in all actuators (linear and rotary) and especially misalignment that results in side loading on linear actuators. Any misalignment will decrease the life of the components within the actuator or create problems with external components or adversely affect performance.



Excessive side load on the output rod of the actuator will dramatically reduce the life of the actuator and should be avoided completely. Side load can be caused from misalignment or loading that is not inline with the actuator output rod.

Stroke length and centering must be carefully considered to avoid hitting physical travel limits in linear actuators, including over travel in fast motion profiles. Homing to end of travel may be done at very slow speed and limited force, but homing manually or to a limit switch, or maintaining continuous Logic Power or using the absolute position feedback option to avoid frequent homing should be considered.



Do not exceed the physical travel limits of T2M Series Actuators. Doing so will result in an internal end-crash that will physically damage the roller screw and the internal components of the actuator.

Lubrication

The T2M and T2X Series linear actuators are shipped from the factory fully greased and ready for installation. Exlar recommends using Mobilith SHC 220, a high performance, extreme-pressure grease. The unique physical properties of the synthetic base oil provide outstanding protection against wear, rust, corrosion and high or low-temperature degradation. For operation below -20°C contact Exlar for special grease & de-rating considerations.

Note: If the actuator with which you are working has a preloaded follower (PF option), do not remove the nut or screw. Contact Exlar Corporation and arrange to have maintenance and/or re-lubrication performed on the actuator by an authorized Exlar repair facility.

General Operation

The Tritex Series of actuators and motors function in the same manner as a brushless servomotor. The servo amplifier is used to rotate the motor at controlled speed and torque, and for controlled distance. This rotary motion is translated into linear motion by the internal planetary roller screw mechanism of the T2M / T2X Series linear actuator.

The rotary motion of the motor and the linear motion of the actuator correspond to the following relationships:

$$\text{Linear Distance Traveled (in)} = (\text{Motor Revolutions}) * (\text{Roller Screw Lead})$$

(Roller Screw Lead)

$$\text{Linear Speed (in/sec)} = ((\text{Motor RPM}) / 60) * (\text{Roller Screw Lead})$$

(Roller Screw Lead)

$$\text{Linear Force (lbf)} = ((\text{Motor Torque (in-lbf)}) * (2\pi) * (\text{efficiency})) / (\text{Roller Screw Lead (in)})$$

All of the above relationships require proper anti-rotation of the actuator rod.

Mounting Configurations

The standard configurations available are Rear Clevis, Side Mount, Side Trunnion and Front Flange (See Model Mask and ordering guide in the General Specifications section). Mounting dimensional drawings in the following pages:

T2M Series Linear Actuator Anti-rotation Option

The unique design of the T2M Series linear actuators allows the extending rod to rotate. This simplifies the setup of the actuator by allowing the user to rotate the rod and thread it in and out of the actuator for mechanical attachment or system testing.

This feature also requires that the rod be kept from rotating when used in its dedicated application to insure proper linear motion. In most applications, such as those where the load is coupled to linear bearings or some other support device, the load cannot rotate, providing anti-rotation for the extending rod of the actuator.

For applications in which the load is free to rotate, Exlar offers the anti-rotation systems shown in drawings following the mounting dimension drawings. The drawings show the rod and bushing on only one side of the actuator. For long stroke actuators, the rod and bushing are require on both sides of the actuator.

Outdoor and Wash Down Installations.

Tritex ingress ratings: The T2M075 with the P5 option, T2X075 and RDM/G075 actuators has been tested to IP 66. **Tritex actuators are not intended for applications where the actuator could possibly be submerged.**

1. Avoid rod/shaft up installations if possible; if not possible, make external provisions to keep rod/shaft exposure to water to a minimum. When new, the seals are effective to IP 66 or better. However over time, depending on the amount of side load, they can wear and eventually allow moisture to ingress. Contact Exlar application engineering for special options.
2. With the NPT connection option use thread sealant or Teflon tape on the connector/conduit threads.
3. If straight metric conduit connection is used verify the connector/fitting IP rating and verify the connector O-ring is in place.
4. If cord-grip type cable glands are used, the type with soft rubber glands are preferred (IP 68). The firmer rubber can cause the cable to compress over time, compromising the seal between the gland and the cable. Cable strain reliefs should also be considered to assure tension, bending radius or flexing of the cable over time does not compromise the seal. Careful consideration and testing is required when these glands are used in outdoor or wash-down applications.
5. If the I connector option is used verify the connector plugs are properly sealed and have the desired IP rating. During installation be sure to screw the plug all the way on to the receptacle for proper sealing.
6. Position conduit fittings or loop cable / flexible conduit so water does not drain towards the conduit fitting.
7. When the wire termination cover is re-installed verify the gasket is in place and the surfaces of the gasket as well as the cover are free from debris so a good seal can be achieved. If the gasket is missing, replace it with PN 51530.
8. When re-installing the termination cover tightens all 4 screws evenly to be sure the cover seats flat. Tighten the screws to assure the cover is securely held against the gasket. Caution, over tightening can strip the threads in the enclosure. If a screw is missing replace it with Exlar PN 01185. (4-40 x ¼ Button Head Cap Screw, Stainless Steel)

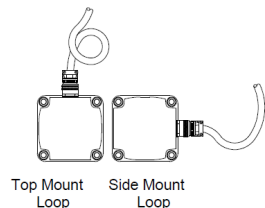

9. The T2M/X, R2MG 075 actuators have conduit hole plugs to cover unused conduit entries, verify they are all tight.

Manual Drive Operating Instructions

WARNING



Isolate all sources of energy to prevent safety hazard due to unexpected motion

System design and operating procedures must ensure that the drive will have no unintended motion that can create a hazard to personnel when operating the drive manually. This includes electrical energy turning the motor as well as energy stored in a vertical load or spring.

There are two manual drive options available on the Tritex, Hand Wheel (HW) and Side Drive (SD)

The hand wheel option includes an internal switch that is closed when the hand-wheel drive is fully disengaged and opens when an attempt is made to engage the hand wheel drive. This switch is in series with the actuator over-temperature sensor to form a combined run permissive signal. When manual drive is engaged, an Actuator Over-temperature fault occurs. The fault action for this fault will disable the drive.

This function is not safety rated, so is not usually sufficient to ensure safety. Power to the drive must be isolated before manually operation.

The Side Drive does not include an interlock switch so power must be removed before use.

CAUTION



Important information to avoid damage to the manual drive

- If manually driving with a brake engaged or high force is necessary, please consult Exlar Application Engineering.
- If a power tool is used to operate the manual side drive the speed should be limited to 600 RPM
- An impact driver should never be used to operate the manual side drive.
- Determine end of stroke of actuator or system and do not apply force past it.
- Refer to **Table 1** for maximum torque specifications.

Side Drive Instructions

- 1) Isolate all sources of energy from the drive
- 2) Press down on the hex until you feel you have bottomed out the manual drive. **Constant downward force is required to maintain engagement during operation.**
- 3) Give the hex a slight turn while observing if you are moving the rod or not. It is possible that during engagement the gear teeth have not completely engaged; this will prevent the gears from meshing. If the rod is not moving continue to press down while turning the manual drive slowly until it pushes farther down. When this happens you have proper gear engagement.
- 4) After gear engagement is achieved, the manual drive can be operated. **The maximum torque input for the manual drive should not exceed 30 in-lbs (3.4 Nm).**
- 5) When the manual drive movement is completed, cease the downward force and the manual drive will disengage.

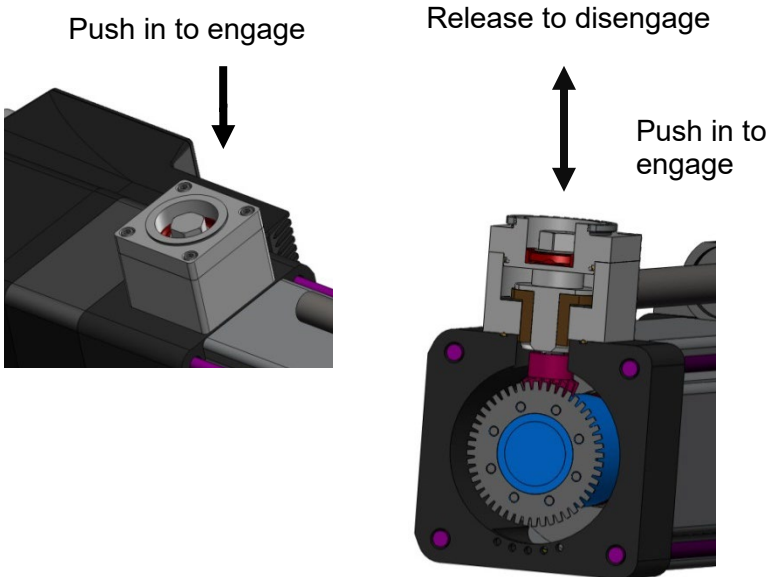

Electrical Installation

Introduction

All of the required power components, motion processor, and I/O and communications ports are contained in the actuator or motor housing.

The following diagram shows the electrical connections schematically:

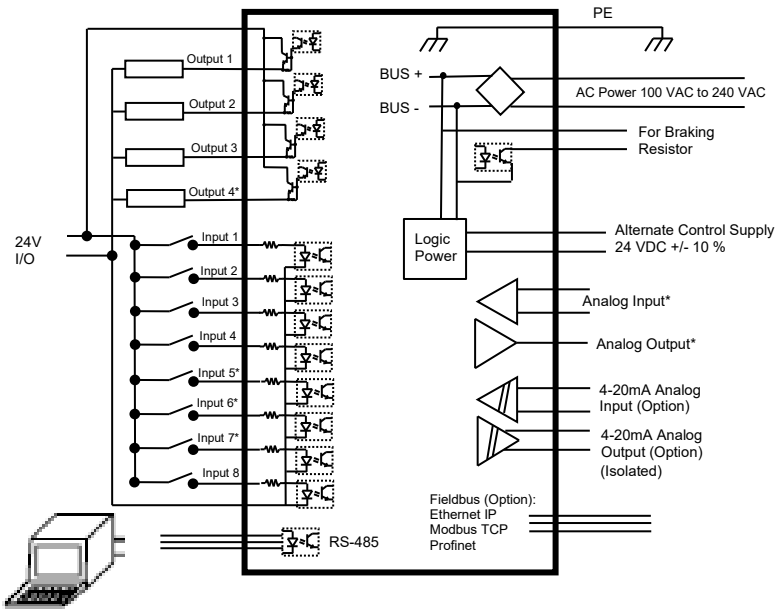

Cable Entry

Several cable entry / connector options are available.

All standard models include four M20x1.5 threaded holes machined into the electronics housing for cable entry, two in the top and two in the rear. The two holes in the top will be plugged with removable hole plugs. The user is free to use these holes as needed as long as any unused holes are re-sealed to prevent water or dust intrusion (see note). The cover is removable for customer wiring to IO and power terminals. See wiring section below.

NOTE: Torque M20 plugs on unused holes to 45 in-lb for proper sealing. Plumber's putty can be used as a redundant seal, but is not required.

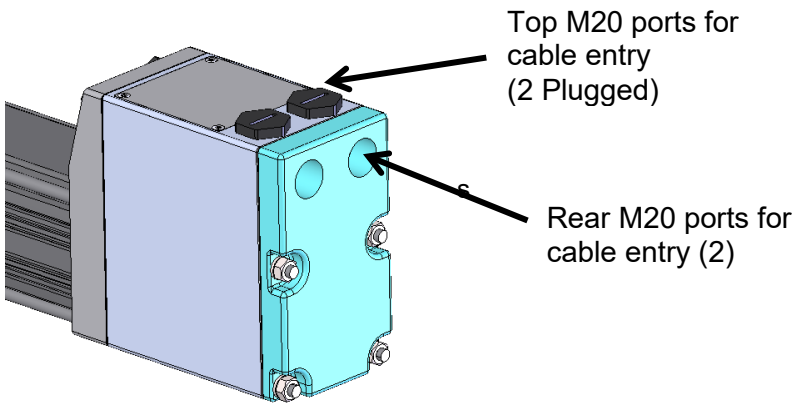

M20 Cable Entry Ports

- G Connector Option: the rear entry holes are open for customer installation of M20x1.5 conduit fittings, cable glands or connectors.
- N Connector Option: the rear M20x1.5 holes each have a ½ NPT adapter installed. When using NPT ports always use Teflon tape or a quality thread sealant.
- I Connection Option: Includes and M23 power connector and an M23 IO connector installed in the rear holes and wired, see wiring sections below. Note the IP rating is valid only when the cable/ plug is installed.
- J Connector Option: The same as B with M23 Plugs connected to the end of the cables.

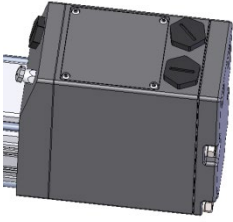

G Option

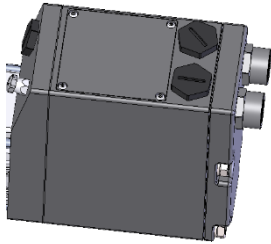

N Option

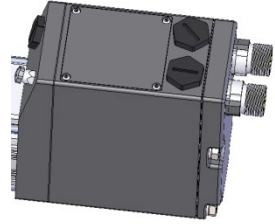

I Option

A PG 9 hole is also machined in front of the electronic enclosure. This hole is used for the Ethernet or CAN communication connector. If these options are not selected this PG9 hole is available for customer use.

PG 9 Port, shown plugged
w/o Ethernet or CAN option

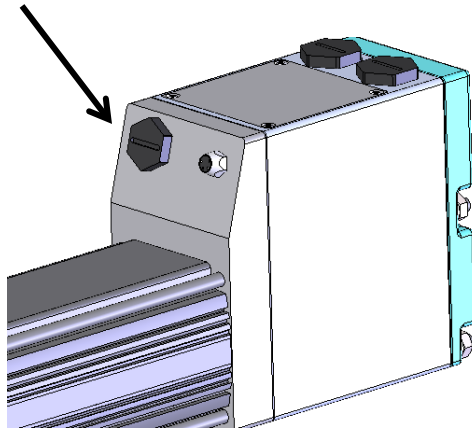

PG9 Cable Entry Port/ Communication Connector

WARNING



Grounding

Fixed Protective Earth (PE) connections are required for human safety as well as proper operation. PE connections must not be fused or interrupted. Failure to follow proper PE wiring can cause death or serious injury. This equipment has high earth leakage current and requires a redundant PE connection to comply with EU Low Voltage Directive.

There are two PE terminals provided on the power terminal block under the wiring access cover.

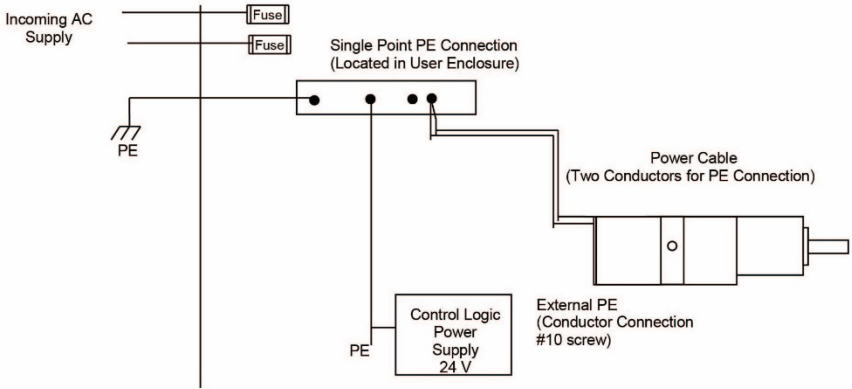

Grounding Schematic

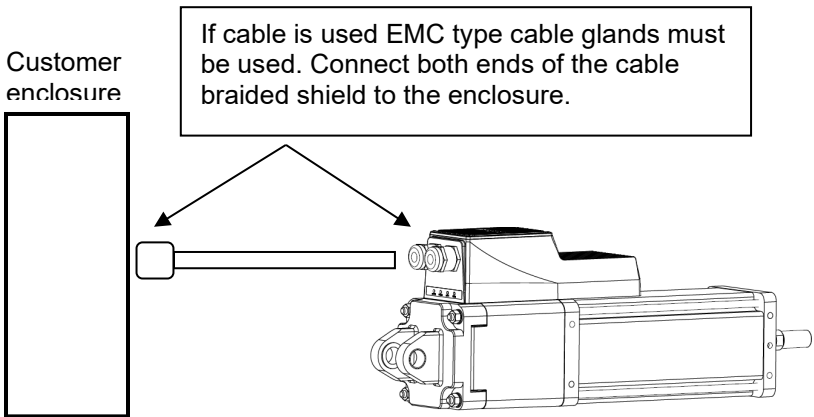

Grounding Diagram

Shielding

In order to meet the European EMC Directive for an installation and to provide immunity from radio frequency (rf) interference and to minimize rf emissions, the power and I/O wiring or cables must be shielded. Metallic conduit (solid or flexible) can serve as a shield. Shields must be connected to the enclosure at the entry / exit point. This is most easily accomplished with EMC type cable glands.



When the “I” connector option and Exlar cables are used this function is included in the cable/ connector construction at the actuator end.

CAUTION



Avoid Loose Conductive Material

Always apply tape or heat shrink to the end of the shield to prevent strands of the braided shield from breaking off and shorting internal electronics or compromising spacing.

AC Input Power

Tritex II actuators require 100 VAC to 240 VAC (nominal) single phase 50/60 Hz to operate. The following sections contain important information on ratings, acceptable power sources and connections, situations requiring isolation transformers, overcurrent protection (fusing), and details of wiring to power terminal blocks or connectors.

See diagrams below for connections to 3 phase and single phase power sources.

The AC supply must be earthed with PE connected to the earthed point at the source. In terminology used in the EU, Tritex II must be connected to a Type TN system, and must not be used on a Type TT or IT system without an isolation transformer so that the secondary can be earthed.

Input Power Ratings

The following table shows rated input voltage and current. The maximum voltage applied to the Tritex terminals must not exceed 264 VAC phase to phase or phase to PE ground. Operation on less than rated voltage results in proportionally reduced maximum speed. Refer to Torque/Speed diagrams in catalog for additional information.

Actuator Size	Input Voltage (Volts ac)	Frequency (Hz)	Input Current at rated output power (Amps rms)	Inrush Current (Amps)
75mm	240+/-10% 1 Φ	47-63	6.7	50 (<5 msec)

AC Supplies NOT Requiring Transformers

If the distribution transformer is configured as shown in the figures below, the AC power supply can be connected directly to the actuator terminals without an isolation transformer.

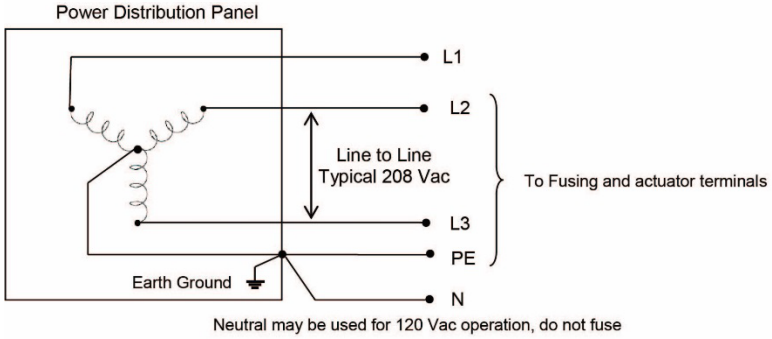

Grounded WYE Power Connection, 120/208Y 3Φ

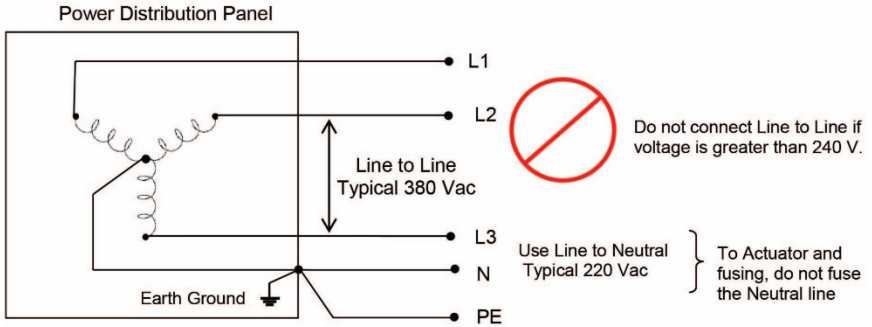

Grounded WYE Power Connection, 220/380Y 3Φ

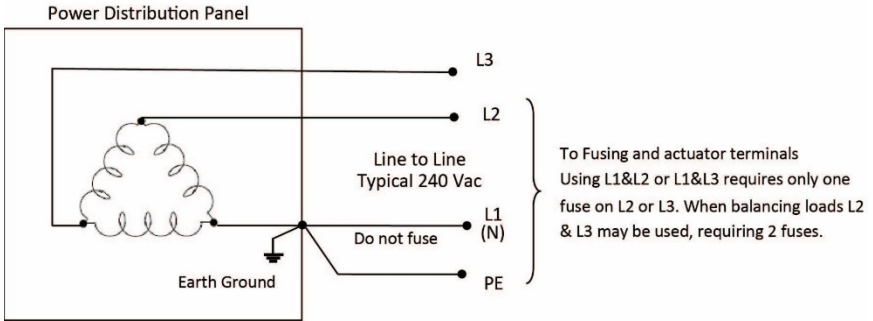

Three Phase Grounded Delta Power Connection, 240 VAC

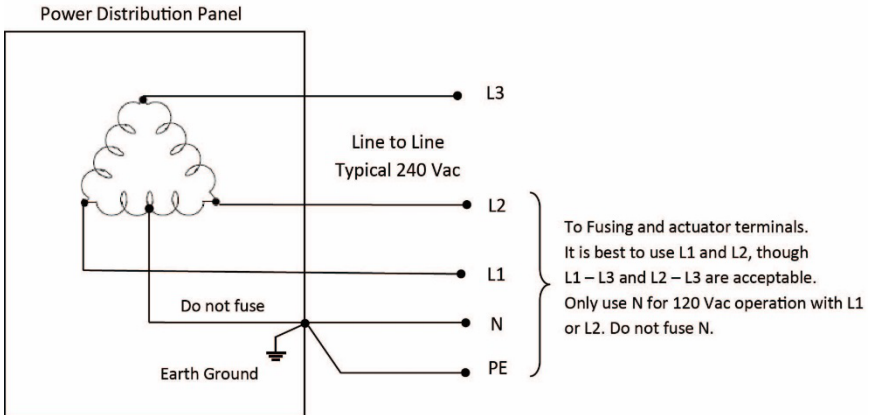

*Three Phase Delta with Mid-Phase
GND Power Connection, 240 VAC*

AC Supplies Requiring Transformers

If the power distribution connection is configured as shown in the figures below, an isolation transformer must be installed between the power distribution and the actuator. The isolation transformers secondary must be grounded for safety reasons. Do not use buck-boost type transformers.

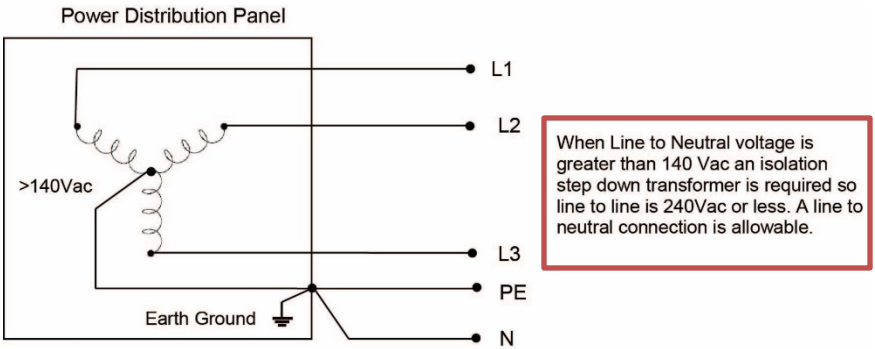

Grounded WYE Power Distribution with > 140 VAC Line to Neutral

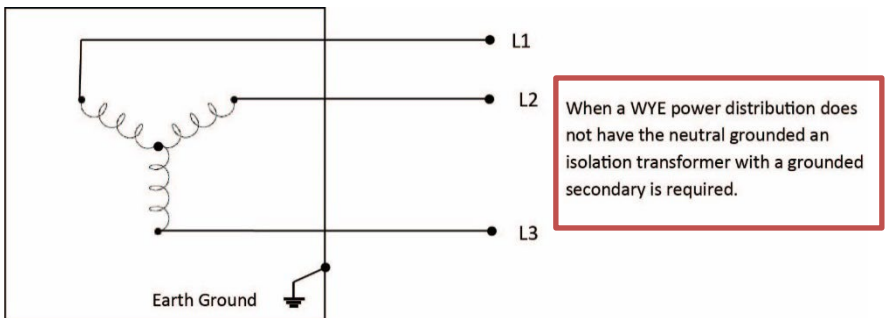

Ungrounded WYE Power Distribution

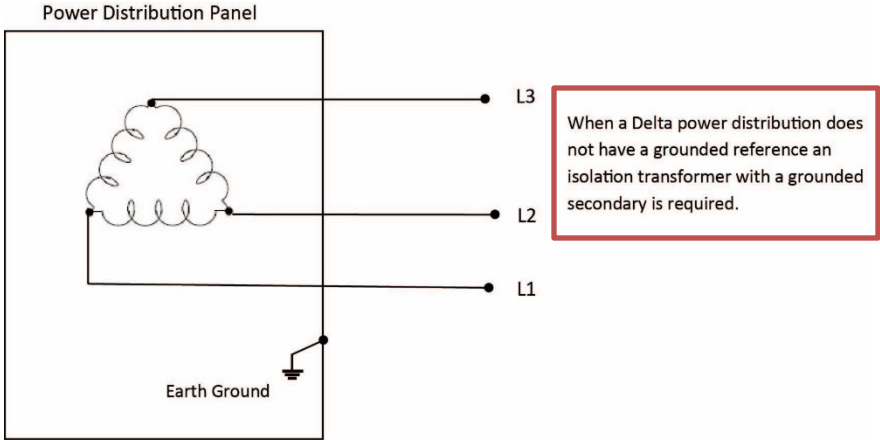

Ungrounded Delta Power Distribution

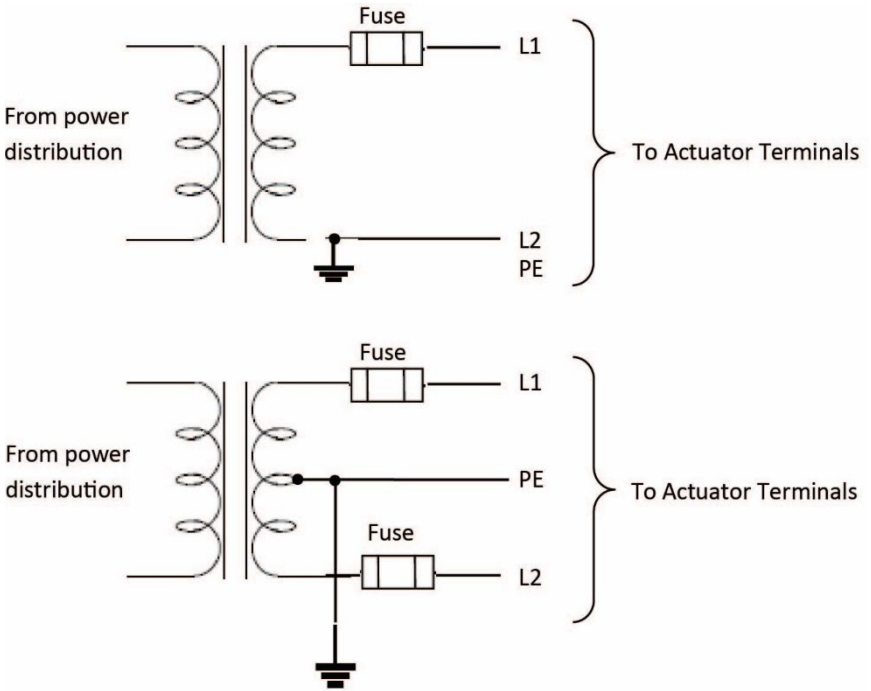

Single Phase Isolation Transformer Connections

Wire Size, Branch Circuit Protection and Overcurrent Protection

Drives must be protected by non-semiconductor fuses or inverse-time circuit breakers only. The table below lists approved fuses or circuit breaker and the manufacture:

Actuator Size	Required Wire Sizes for L1, L2 and PE (two wires required)	Fuse or Circuit Breaker				
		Fuse Class / Circuit Breaker Input Protection	Littelfuse	Cooper - Bussman	Mersen (Ferraz-Shawmut)	Schneider Electric
75mm	14 AWG or ISO 2.5mm ²	Class CC, Fast Acting (15A, 600Vac)	KLKR 015	KTK-R-15	ATMR15	-
		Class CC, Time Delay (15A, 600Vac)	CCMR 015	LP-CC-15	ATDR15	-
		Class RK1 Fast Acting (15A, 250Vac)	-	KTN-R-15	A2K15R	-
		Class RK1 Time Delay (15A, 250Vac)	-	LPN-RK-15SP	A2D15R	-
		Inverse Time Circuit Breaker (15A, 240Vac, 2 Poles)	-	-	-	60146

Power Terminal Wiring

Refer to the diagram below for connections to the main power terminal block.

WARNING



Check All Connections Before Applying Power

Connecting AC Power to any terminals other than L1 and L2 will severely damage the actuator and such damage is not covered by warranty. Connecting a 24 VDC source to L1, L2, R1 or R2 in error can result in a shock hazard or damage at connected equipment. R1 and R2 may connect only to a braking resistor.

WARNING



Dangerous Voltages Present After Main Power Removed

Braking resistor connections R1 and R2 remain at dangerous voltage after disconnection of AC Power. Power must be “Off” for a minimum of 6 minutes before touching these terminals.

CAUTION



Use Correct Wires and Terminations for Power Wiring in UL Installations.

L1, L2, PE, R1 and R2 connections should be 14 AWG / 2.5 mm, 300V, 105°C minimum. If ferrules are used with 14 AWG wire a precise crimp is required. The crimped ferrule must measure less than 2.1 mm on each side of the ferrule or it will not fit into the terminal opening.

The terminals are lever actuated spring terminals that retain high and constant contact force on any wire through thermal cycling and do not require measured torque to avoid over-tightening or under-tightening. To operate, use a small flat bladed screwdriver in the indentation in the lever. Press down on the lever at approximately a 45° angle with only enough force to open the clamp, the clamp will full open with about 8 lbs of force, insert the wire, and release the force on the lever. Check that the wire is in position with insulation partly into the lead-in window, but not into the clamp area.

CAUTION



Do not apply direct vertical force or excess force on the terminal levers. A force of 8 lbs at a 45° angle is sufficient to fully open the wire clamp, applying a force in excess of 12lbs can damage the terminal.

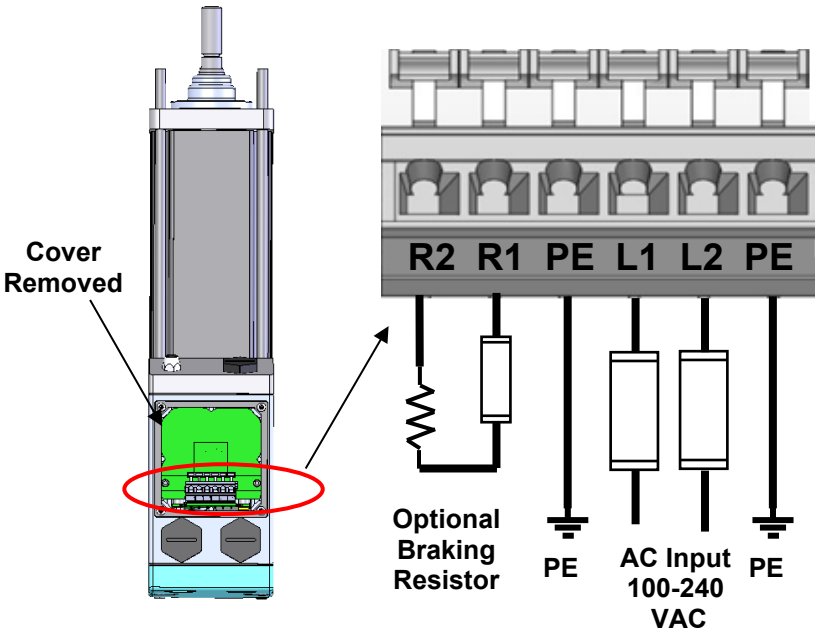

Internal Power Terminal Block Connections

Power Connector Wiring

Refer to the following table for standard pre-wired power connector, part of Option “I”.

WARNING



Dangerous Voltages Present On Connector Pins #4 and #5

Pins #4 and #5 connect to terminals R1 and R2 for use with a braking resistor and have dangerous voltages present under normal operation and for up to 6 minutes after main power is disconnected. Conductors attached to these pins must be terminated at the user end of the cable to avoid shorting even when a braking resistor is not used.

Power Wiring for “I” option - M23 power connector

Function	Pin	Internal wire color	Cable wire color	Function	Pin	Internal wire color	Cable wire color
L1	1	Black	Brown	R1	4	Red	Orange
L2	2	Black	Blue	R2	5	Blue	White
Drain/ Coupling	3	n/c	Drain	PE	6	Green	Grn/Yel

Note: See Cable section for cable details



Actuator view

Over Temperature Protection

UL approved motor over temperature sensing is not provided by the drive.

The motor contains a UL recognized temperature sensor embedded in the stator windings when it reaches 130°C the controller generates a fault condition and disables the drive. This sensor is permanently connected to the Tritex drive and will generate an Actuator over temperature fault.

The drive also provides motor over temperature protection by limiting the continuous current to the motor. The continuous current limits are set at the factory and cannot be adjusted. These limits are set to keep the

stator below 130°C while in a stall condition at 40°C Deg ambient. Additional over temperature protection is provided by a sensor in the drive electronics which generates a fault when the board reaches 100°C.

The factory default setting for action when reaching overtemperature and continuous overcurrent limits is to immediately disable the drive to provide drive/motor/actuator or customer tooling protection. The user may override this protection to allow the actuator to move to a safe position before disabling or take similar immediate controlled action. Contact Exlar Application Engineering to enable this functionality.

CAUTION



Do not continue normal operation after reaching temperature or current limits.

If the fault action is other than DISABLE, the user must disable the drive as soon as possible if any of these conditions occur. Failure to act on these conditions can cause permanent damage to the drive or motor/actuator. Such damage will not be covered under warranty.

Brake / Shunt Resistor Considerations

Many applications require a brake (or “braking” or “shunt”) resistor to dissipate energy regenerated from decelerating an inertial load, lowering a vertical load, or relaxing a return spring. There is little energy storage in internal capacitors and Tritex II AC does not return energy to the AC line. With gear motors and linear actuators, inertial energy is often not a significant factor. Vertical loads and return springs must always be considered a source of regenerated energy. A high bus fault will occur if an application requires a braking resistor but does not have one installed.

Terminals R1 and R2 on the power terminal block are provided for connection of an external Brake / Shunt resistor only. Each drive must have an independent resistor connected to only one drive. No other connections are allowed at the R1 and R2 terminals. Refer to the warnings in the Power Terminal Wiring and Power Connector Wiring sub-sections in this document pertaining to these connections.

WARNING



Protection Against Overloaded Brake Resistor Required

It is essential that the external braking resistor be protected against overload caused by a failure of the brake control. The protection can simply open the circuit, such as a fuse or overtemperature switch, or be wired to a contactor that isolates input power to the actuator on an over temperature condition at the resistor. A thermal switch built into the

resistor assembly is best. Fuses are difficult to size properly; the intension on the fuse is not to protect the Tritex, but to protect the wiring and resistor from overheating.

The resistor used must be rated for dynamic braking applications for 240 VAC drives, meaning it is capable of peak working voltage of at least 400V and can absorb high energy within a short period. The minimum resistance is 40 Ohms. Recommended range is 40 to 50 Ohms. A higher ohms value has no advantage and may not be able to keep up with peak regenerative power, resulting in a high bus fault.

It is best to consider the energy in a regenerative event and the time between these events when sizing a braking resistor for energy and power. An example may provide the clearest presentation. A 100kg vertical load is lowered 0.2m in a move repeated every 10 seconds. Since 100kg exerts 980 Newtons, the move results in 196 Nt-m (or Joules) of energy. Assuming roughly 90% conversion efficiency, the regen event results in 180 Joules delivered to the braking resistor. Since this happens every 10 seconds, the average power to the resistor is only 18 W. Though most resistors are not directly rated for energy, short term overload ratings can be used, though these ratings usually are for isolated events where the resistor can fully cool before another event. Using half the energy rating with repetitive events is generally appropriate. A resistor rated 100 W with an overload rating of 2 times continuous for 5 seconds which is 1000 Joules would be able to handle repetitive 500 Joule events, so would be adequate for the application.

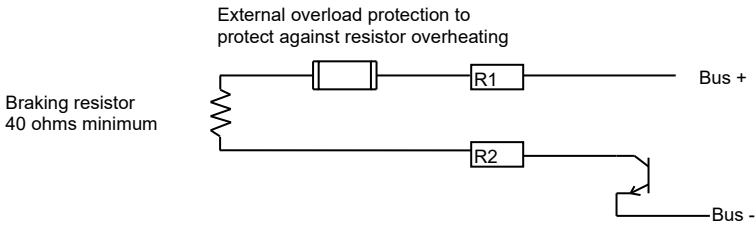

Braking Resistor Connections

Logic and IO Power Supply

The 75 mm Tritex contains a built in 24 Volt power supply, this supply can be used to power the optional internal brake as well as provide some power for the IO. The maximum current the internal 24 V can provide is 600 mA. The brake will use 500 mA that only leaves 100 mA available for other IO if a brake is provided.

Optionally an external 24 VDC power supply may be connected to the IO+V and IO Com connections, see diagram below. When an external 24 Volt supply is connected it effectively bypasses the internal 24 Volt supply and provides power for logic backup, IO and the brake. If the external 24 Volt supply remains powered when the main Tritex AC power is removed it will maintain position information (position feedback is still powered and active) so re-homing is not required and keeps communications active to networked system components. A fuse is necessary unless power supply self-limits at 3A or less.

Control Logic Power Supply Wiring and Fusing

Volts	Amps	Fuse	Wire
24V dc +/- 10%.	1	2 Amp, if power supply is not limited at 3A or less	18 AWG (0.8 mm ²)

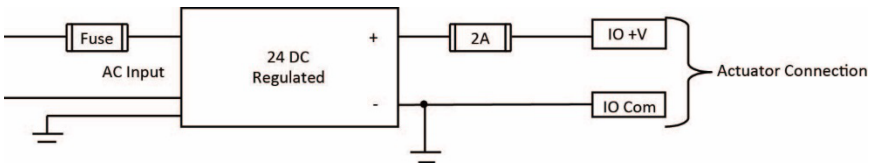

Wiring for External 24 Volt Supply

CAUTION



It is important that the 24 VDC power supply or logic and I/O is connected to the circuit common and also shall be externally grounded to PE.

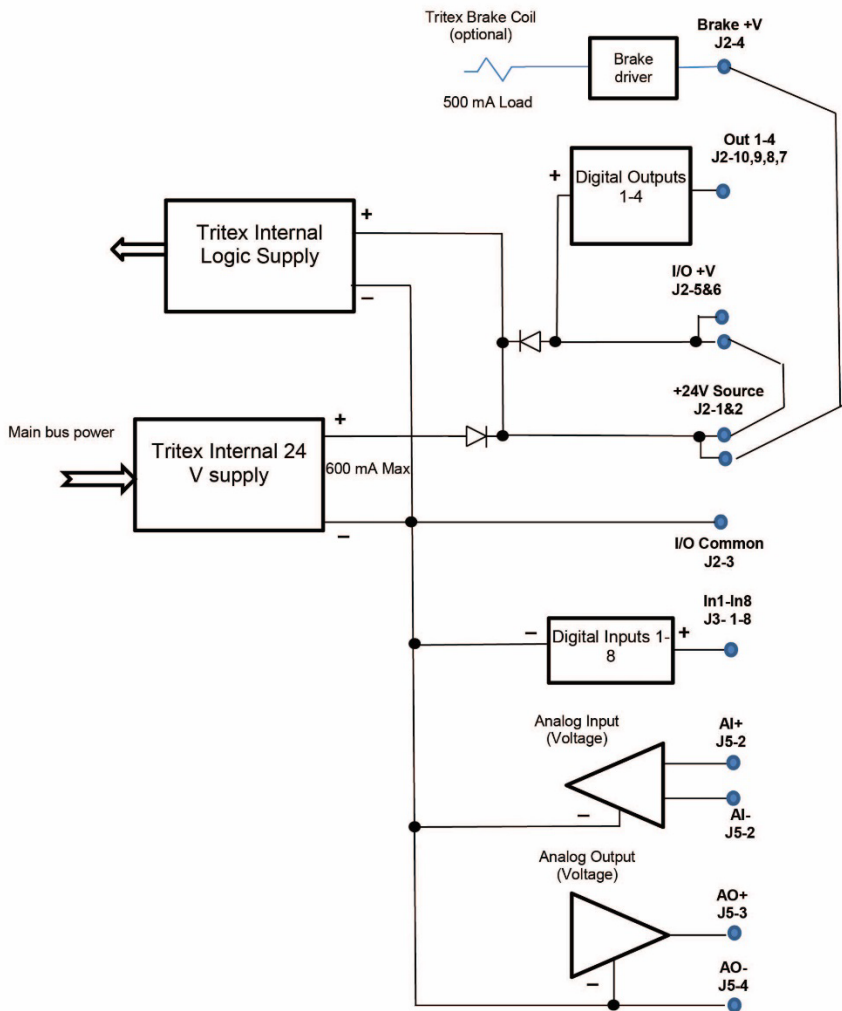

Block Diagram of 24V IO and Logic Supply Connections

Tritex Input and Output Wiring

Input / Output Connections with M23 connectors 19 Pin I/O Connector for I Connector Option

FUNCTION	Pin for "I" Connector Option	Wire Color Code TTIOC Cable and "B" Connector Option
INPUT1	1	White/Yellow
INPUT2	2	White/Red
INPUT3	3	White/Green
INPUT4	4	White/Black
*INPUT5	5	Red/Black
*INPUT6	7	Red/Green
*INPUT7	8	Red/Yellow
*INPUT8	9	Beige
IO + V (+24V)	6	Red
IO com	19	Black
*ANALOG IN+	10	Green
*ANALOG IN-	11	White
*ANALOG OUT +	13	Blue
*ANALOG OUT reference	14	Orange
OUTPUT4	15	White/Brown
OUTPUT3	16	White/Orange
OUTPUT2	17	White/Blue
OUTPUT1	18	Light Red
Shields	12	Drains

* For the IA4 option Inputs 5, 6, 7 & 8 and Output 4 are removed. The analog voltage input and output are replaced with 4-20 mA input and output. For the CANopen option Inputs 5, 6, 7 & 8 and Output 4 are removed. The analog voltage input and output are also removed.

Front View “I”
Connector Option



Input / Output Connections

Terminal board connections

J3 Terminal #	Function	J2 Terminal #	Function	J5 Terminal #	Function
1	INPUT 1	1	+24V Source	1	*Analog IN+
2	INPUT 2	2	+24V Source	2	*Analog IN-
3	INPUT 3	3	I/O Common	3	*Analog OUT
4	INPUT 4	4	Brake +	4	*Analog REF
5	*INPUT 5	5	I/O +V	5	RS485+
6	*INPUT 6	6	I/O +V	6	RS485-
7	*INPUT 7	7	*Out 4	7	RS485 COM
8	*INPUT 8	8	Out 3	8	PE
9	PE	9	Out 2		
10	PE	10	Out 1		

* For the IA4 option Inputs 5, 6, 7 & 8 and Output 4 are removed. The analog voltage input and output are replaced with 4-20 mA input and output. For the CANopen option Inputs 5, 6, 7 & 8 are used for CAN communications and Output 4 is removed. The analog voltage input and output are also removed.

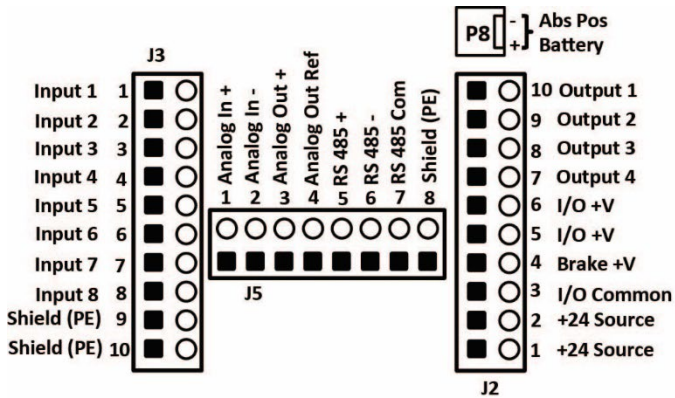

SIO and Ethernet Option

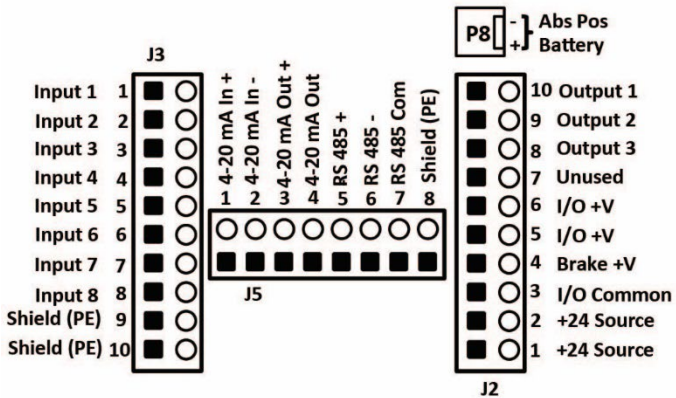

IA4 Option

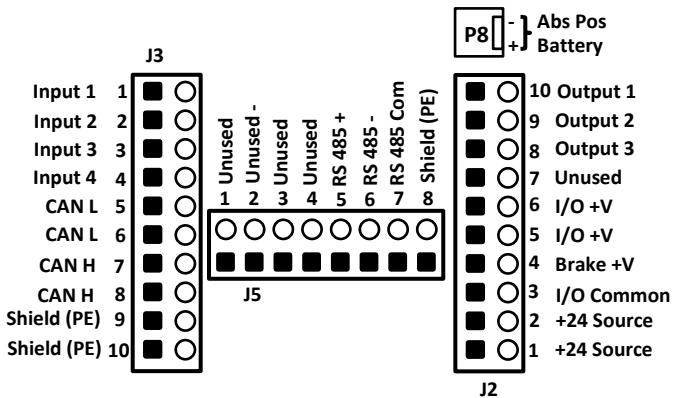

CANopen Option

Digital Inputs

Tritex digital inputs are optically isolated from drive main power, but have a common negative side. SIO and Ethernet options have 8 inputs, the IA4 and CAN options have 4 inputs. They require a positive voltage to turn on, so are compatible with sourcing outputs only. The voltage for the input can be sourced from an external 24 V supply or from the internal 24V supply. Each input can be assigned to any of the internal input functions (see software section). It is important that the external power source common is connected to PE.

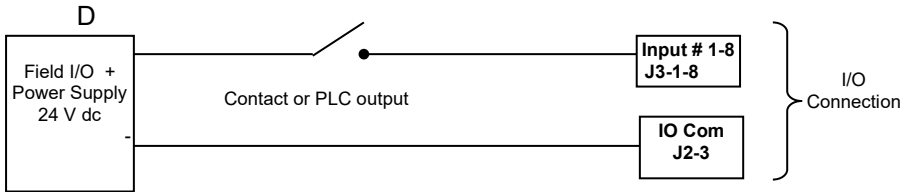

Input Wiring with External 24V Power Supply

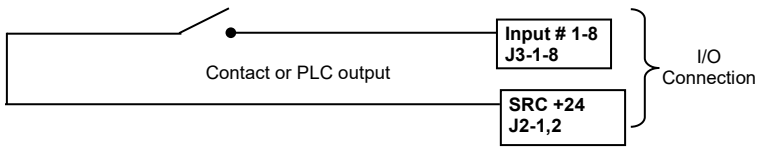

Input Wiring Using Tritex Internal 24V Power Supply

Digital Input Specifications

Description	Specification
Input Voltage Range	0 - 30 V dc
On state voltage range	8 – 30 V dc
Off state voltage range	0 – 5 V dc
On state current	
10V (min)	3.3 mA
24V (nominal)	5.0 mA
30V (maximum)	5.7 mA
Nominal Impedance (24V)	4.8 kΩ
Off state current (max)	2.0 mA
Update rate	1 ms (typical)

Digital Outputs

The Tritex digital outputs are optically isolated from drive main power, but have a common positive side. SIO and Ethernet options have four outputs, the IA4 option has three outputs.. These outputs are sourcing only, they provide a positive voltage when on. The power for the outputs can come from an external 24 V supply or from the Tritex internal 24 V supply. Note: The internal supply is limited to 600mA maximum, if the brake option is used, it requires 500mA, leaving 100mA for remaining IO. The outputs have short circuit and thermal protection, and protection against inductive kick at turn-off. Each output can be assigned to any of the internal output functions (see software manual). It is important that the external power source common is connected to PE.

CAUTION



Each output is rated to continuously drive a 100 mA load and is short protected at 500 mA with automatic reset after the short fault is removed.

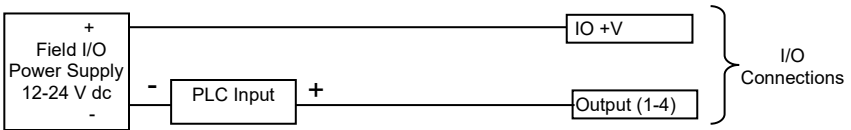

Wiring of Outputs with External 24V Supply for Connection to PLC or Any Load

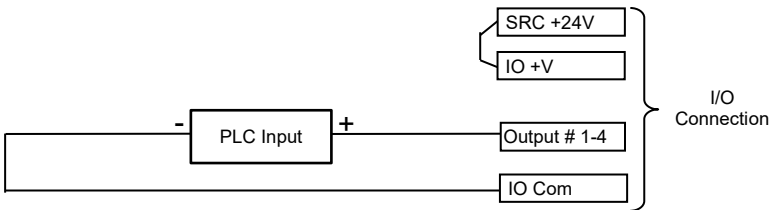

Wiring of Outputs with Tritex Internal 24V Supply for Connection to PLC or Any Load

Digital Output Specifications

Description	Specification
Operating voltage range	0 to 30 V dc
On state maximum continuous current	100 mA
On state voltage drop (@ 50mA)	.5 V typical
Short circuit protection (auto reset)	.5 A
Update rate	1 ms

Actuator Brake Option

The actuators may be ordered with a brake option. This brake is intended as a “parking brake” and is not intended for use as “stopping brake”. The brake engages when the brake voltage is removed. Brake voltage is 24 V +/- 10%. Since the Brake and I/O power supplies are interconnected, use of a brake places additional voltage and power constraints on the I/O supply. The negative side of the brake is connected to the IO common. The brake +24 V can be connected directly to Brk +24 V or through customer interlocks.

When Brake +24 V is applied the brake follows the Tritex Enable function with time delays added. Starting from a disabled status, with brake engaged, when the drive enables, a 0 velocity command holds the motor in position and the voltage to the brake is removed. A 0.2 sec time delay occurs before motion is allowed. Starting from the enabled state, with the brake released or when the drive is disabled for any reason the drive will immediately apply full current, bringing the motor to a abrupt stop and engage the brake, then after a .3 sec delay the drive will be disabled. Brake Release Active status can be assigned to an output, the brake can be manually released, overriding the drives control of the brake, by assigning the Brake override Input function to an Input. See I/O Assignment section of the Software. In some cases it may be required to release the brake without AC power applied, in this case an external +24 V supply is required, the external 24V supply will supply brake voltage and back up logic supply for the brake override input to function.

WARNING



If the brake is released using the brake override function and if AC power is off or the drive is not enabled the load will be free, this may be dangerous in some applications.

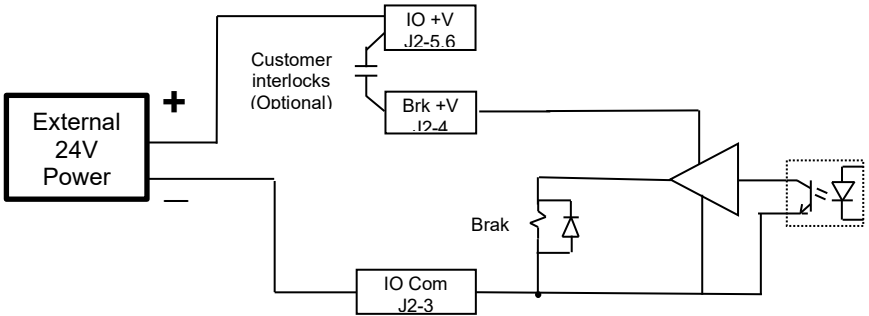

Brake Connections with External 24V Power Supply

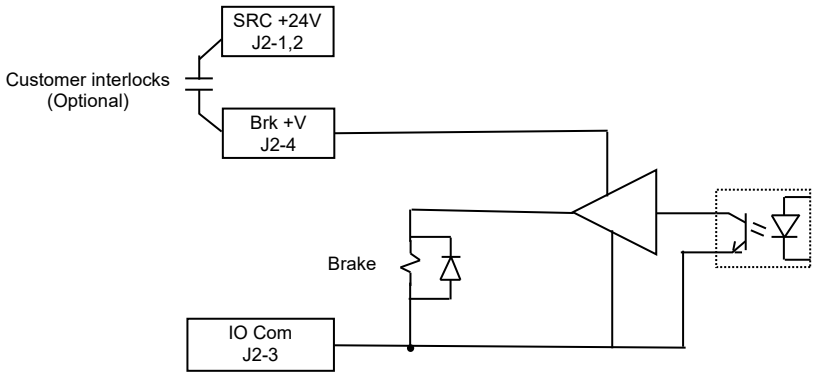

Brake Connections Using Tritex Internal 24V Power Supply

Analog Input

An analog input is provided for use as a position, velocity or current command.

Differential input range is -10 V to +10 V. Input range on Analog IN+ is -15 V to +15 V with respect to IO Common. Input range of Analog IN- is -15 V to +12 V with respect to IO Common. The analog signal must be wired differentially with a return wire to the analog signal source for best noise rejection.

(See software section for configuration of the analog input and analog motion parameters.)

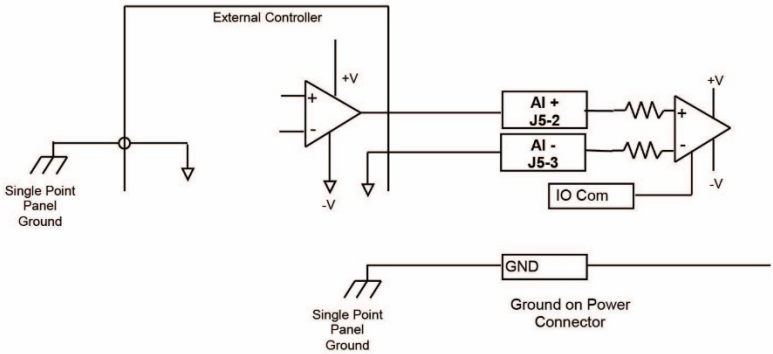

Analog Input Wiring from External Controller

Note: Analog input reference from an external controller must be referenced to single point ground to prevent damage to the analog input circuit.

Analog Input Specifications

Description	Specification
Voltage Input Range	-10 V to +10 V
Input impedance	100 k Ω
Input resolution	13 bits over full -10 V to +10 V range
Update rate	0.5 ms

Analog Output

A 0-10 V analog output is provided. The function of this output is programmable. It can be used for position, velocity or current monitoring.

The intent of this output is to provide a “monitor” type value not a “control” value, meaning the performance is not intended for the user to close a high speed position loop around this signal.

The Analog Reference terminal should only be connected when used with an isolated or differential input. **DO NOT CONNECT TO A GROUNDED POINT EXTERNALLY!**

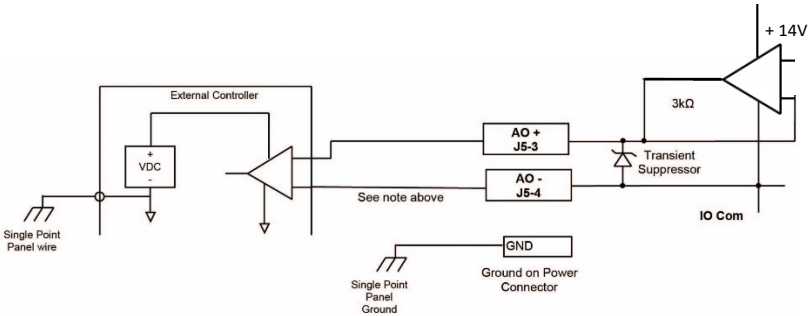

Analog Current Output Specifications

Description	Specification
Current Output Range	0 - 10 V
Load Range	20 kΩ min
Output resolution	11 bits

Communications

Serial communication to the actuator is provided through the 8 mm communication connector on the front of the actuator and also via terminal connection on J5 under the access cover. The serial interface is two wire RS485 network and is isolated from AC power as well as other IO circuits. The actuator supports the Modbus RTU protocol for access to all drive parameters (see Modbus Parameter Reference). The Defaults are settings are: Baud Rate 19.2k, Even Parity, Modbus ID address is 1.

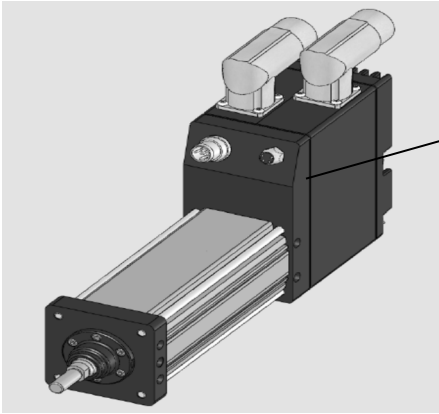

8mm communications connector
Front view



Function	8mm Pin number	Wire color for TTCOM	J5 Terminal #
485+	1	Brown	5
485-	3	Blue	6
485 COM	4	Black	7
Shield	2	Drain	8

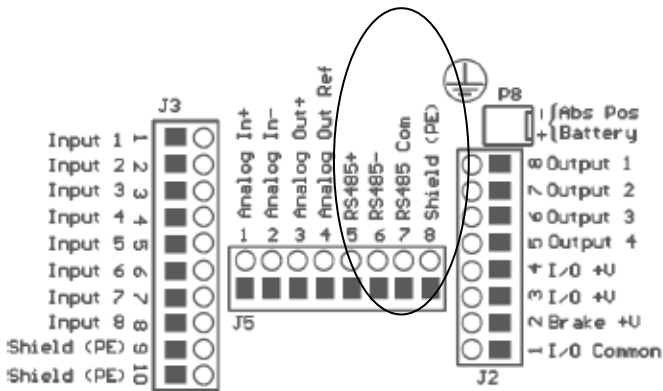

Optional RS 485 Field Wiring

PC Communications

When using the Expert software for set-up and diagnostics an RS485 converter will be required to interface between one of the PC communication ports and the RS485. This can be either a USB to 485 converter, such as the Exlar CBL-T2USB485-M8 or any other standard 485 converter. See Accessories section.

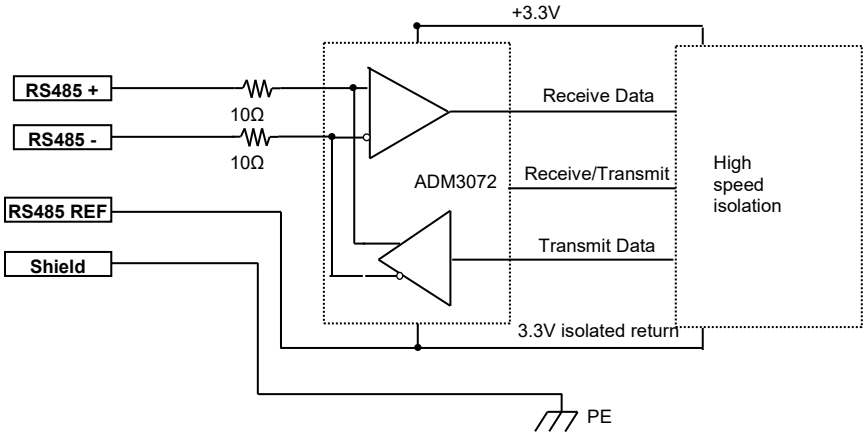

Internal RS 485 Circuit

CAUTION



It is important that the RS485 REF is connected to the circuit common of the converter RS485 output and also be shall be externally grounded to PE. Failure to connect could cause damage to the drive, the converter or the PC port.

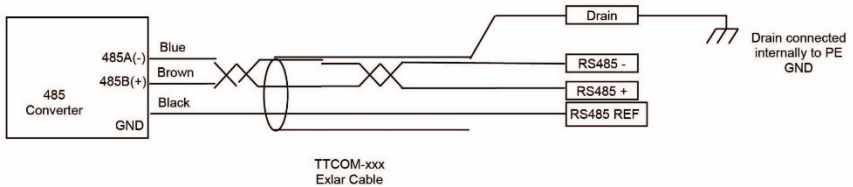

Typical RS-485 Connection to External Converter

Connecting multiple Tritex actuators to a Modbus Master Host

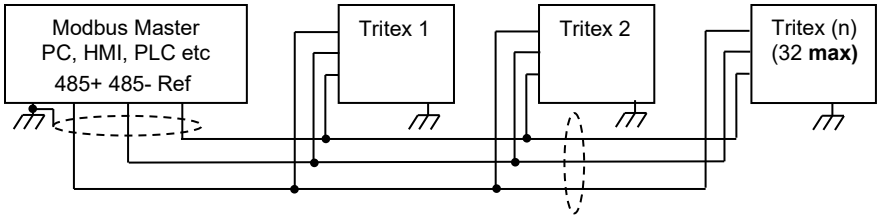

Important considerations

- Always use 3 conductors, RS485 +, RS485 – and Reference.
- A twisted pair for 485+ and 485- is preferred.
- RS485 is a “multi-drop” network as opposed to a “star”, therefore keep the drop (stub) to each actuator as short as possible. When using the 8 mm connector use a T connector, such as the Exlar PN TT458SP.
- A termination resistor is not usually required.

IA4 Option board connections

4-20 mA Isolated I/O, IA4 Option

The IA4 option board replaces the standard I/O board and provides one 4-20 mA isolated analog input and one 4-20 mA isolated analog output; these I/O circuits are isolated from each other as well as all other actuator I/O, grounds and commons. The IA4 option also includes four isolated digital inputs and three isolated digital outputs; this is a reduction from the eight inputs and four outputs available on the standard I/O board.

The 4-20 mA input is a two wire circuit. A small amount of power from 4-20 mA signal is used to generate the internal power supplies needed for the isolation of the input section. This allows the input to float with the Transmitter or loop power supply without inference from the other Actuator grounds or commons. The power supply starts up when the input reaches 3mA. When the 4-20 mA loop is unpowered, the software reads an off-scale high value that should be configured to indicate a “Loss of Signal” condition.

4-20 mA input connection

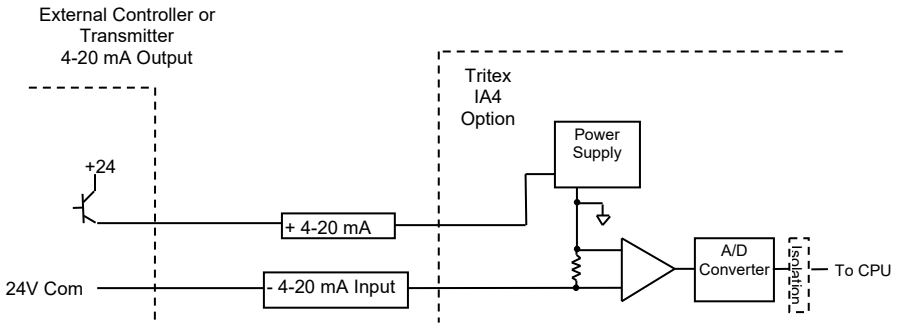

Connection to High Side Controller

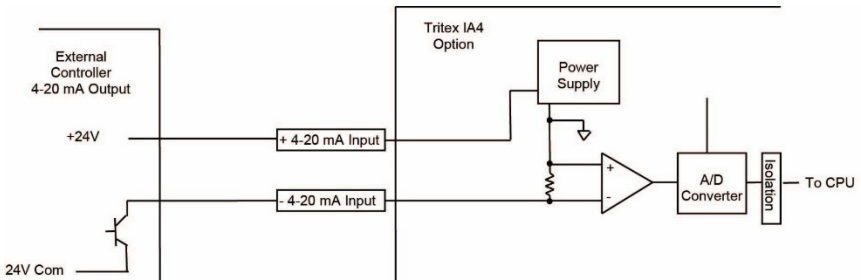

Connection to Low Side Controller

4-20 mA Input Specifications

Description	Specification
Input Range	2 mA to 22 mA (Loss of Signal condition <2.0 mA)
Voltage drop at 20mA	11V typ
Input Resolution	>14 bits over 4-20 mA range
Update Rate	0.5 ms

4-20 mA Output

The 4-20 mA output is a two wire circuit; it requires an external loop supply of 12 to 30V DC to generate the isolated supply voltages needed. The Tritex circuit requires 8V to operate; therefore the max impedance the output can drive is dependent on the loop supply voltage. If the drive is powered down, the output goes to an off-scale low output approximately 2mA.

Loop Supply Voltage	Maximum Impedance @ 20 mA	Minimum Impedance @ 20 mA
12 V	200 Ω	200 Ω
15 V	350 Ω	200 Ω
24 V	800 Ω	200 Ω
30 V	1100 Ω	200 Ω

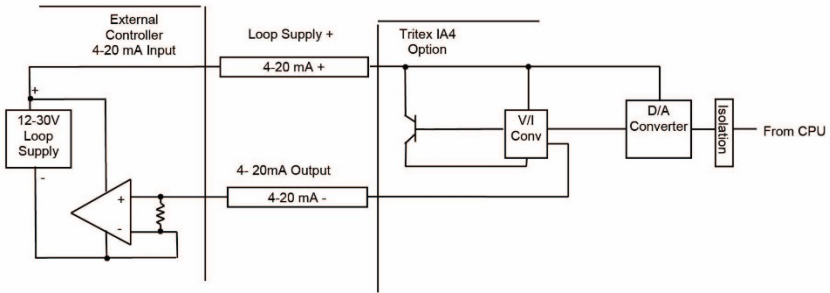

4-20mA Output Connection

4-20 mA Output Specifications:

Description	Specification
Output Current Range	3 – 21 mA
Load Range	200 to 1100 Ω (see table above)
Output resolution	12 bits
Update rate	0.5 ms

AF Option, Absolute Feedback

The Tritex absolute feedback consists of a combination of the standard hall feedback and a low power battery-backed multi-turn counter. The counter will track the motor's position, as long the battery voltage is present.

Battery life information:

Battery Life is typically 2 years from time of product purchase.

Low battery voltage:

When the battery voltage gets below 3 V, a low battery condition will be set. This condition is typically set to generate a warning status on the Fault Enable tab of the System Setup page. The warning status can then be assigned to one of the outputs. The battery voltage can be displayed on the Diagnostic page while on-line with the actuator. When battery voltage gets too low to maintain the count value the Homed Status will be off on the subsequent power up, requiring the actuator to be re-homed. A low or dead battery does not keep the system from running it just means a Home is required.

Replacing the battery:

Remove AC power, then remove the wiring access cover, pull the battery out of the clip, and unplug the harness from the two pin connector. The replacement battery kit is Exlar P/N 54108. The T2BAT1 kit (Exlar P/N 42712) for Tritex AC actuators will work, but outer sleeve on battery must be removed to fit well in clip.

WARNING



High Voltage is present, remove AC power before attempting to replace the battery. Replacement battery assembly is Exlar PN 54108 or 42712.

Replacement with any other battery will violate UL and CSA certification.

Important Note for units built before 2016:

If the battery is removed with both Motor and Logic power also removed, do **not** reconnect the battery and leave all power **off** for **4 minutes**. Once all power is removed from the battery backed logic it must be allowed enough time to completely bleed down before restarting. Once power is re-applied the home position must be reestablished.

CAUTION



Travel limitations:

The counter has a range of +/- 4096 motor revolutions; therefore the actuator must operate within this range. If the actuator is moved beyond this point a Position Tracking Fault will occur on the subsequent power up. The only way to reset this fault is to remove the battery connection for about 20 seconds with all power AC, and Auxiliary DC if used, removed. On the subsequent power up the fault can be cleared and the home position must be re-established.

Ethernet Options, EIP, TCP or ProfiNet IO

The Ethernet Options EIP, PIO, or TCP in the model mask provide an Ethernet rated M12 connector for connection to the Network at the rear of the actuator.

An IP 67 4-pole M12 D coded connector is used, this type of connector must only be used with two pair cables. When the Ethernet connection is made via an Ethernet switch or hub a straight through cable set must be used. If there is a single node connection direct from the Ethernet PC/PLC to the Tritex then a crossover cable may be required. Some PC Ethernet cards have capability to detect a crossover connection. See Expert Software manual for setup of Tritex Ethernet parameters and Ethernet/IP or ProfiNet IO manuals for network specific setup information.

Cord sets

	Signal Name	
1	Transmit + (TX+)	Pair
2	Pin	
3	Receive + (RX+)	Pair
4	Receive - (RX-)	

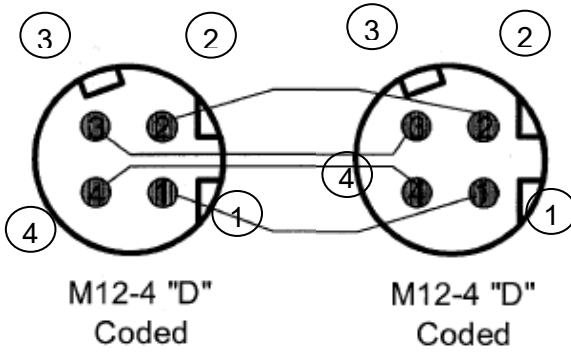

M12 D Coded Straight Through Cord Set

8-Way Modular	M12	Signal	
1	1	TX+	Pair
3	2	TX-	
2	3	RX+	Pair
6	4	RX-	

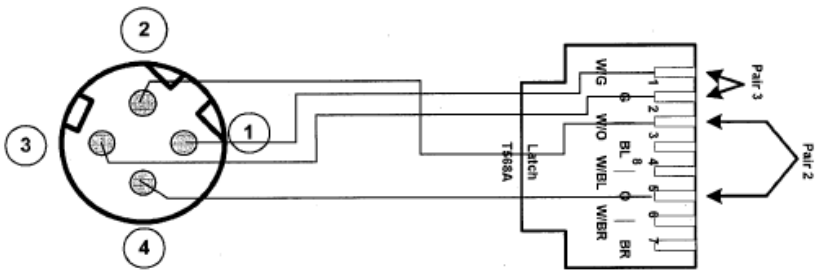

*Conversion from M12 D Coded to 8 Way Modular
Straight Through Cord Set*

For Options EIN, PIN or TCN in the model mask the M12 connector is not included; the Ethernet CAT 5 cable must be routed through the M20 IO port. The installer must then crimp on an RJ45 8 way Modular connector for installation to Ethernet port inside the wiring access area.

8-Way Modular	Signal	
1	TX+	Pair
3	TX-	
2	RX+	Pair
6	RX-	

Shielded or Unshielded Cables

The Tritex can be used with either shielded or un-shielded Ethernet cables. **If a shielded cable is used it is important that the shield is not connected at the Tritex M12 end of the cable. Off the shelf shielded Ethernet cables with M12 connectors usually connect the shield through the M12 connector coupling nut, be sure the shield is not connected to the Tritex end of the coupling nut.** The Tritex M12 connector is in direct contact with the enclosure which is connected directly to PE. Typically the shield should be connected to PE at the switch or hub end only. Connecting the shield at both ends can cause ground loop noise on the shield which can degrade communication performance.

For more details on the installation of an Industrial Ethernet network download the EtherNet/IP Media Planning and Installation Manual, found in the EtherNet/IP library at www.ODVA.org

CANopen

The CANopen circuit is optically isolated from the drive main power as well as other IO power.

There are two methods of connecting to the Tritex with the CANopen option. If the COP option from model mask is chosen a single five pin 12 mm connector (Turck FS 57-.1) will be presented to the user for connection or “T-ing”.

If the CON is chosen no connectors are provided, user wiring can be passed through the conduit port and inserted into connectors on the termination board, see below. A 120 Ω resistor is installed from the factory, in J3 pins 6 & 7, as a termination resistor and can be removed for daisy chaining or changed to another value if desired.

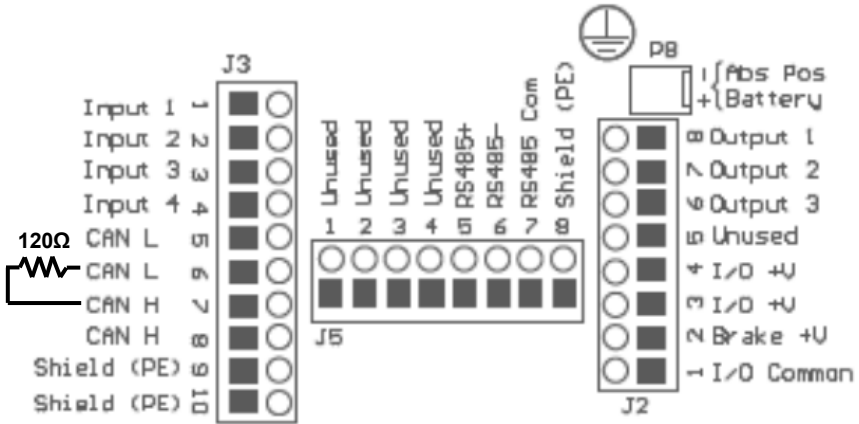

CON Option

Male

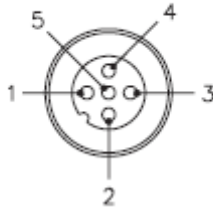

Signal	Pin	Color
CAN H	4	White
CAN L	5	Blue
Shield	1	Gray

COP Option

MAINTENANCE PROCEDURES FOR RE-GREASING

Maintenance Procedure for Roller Screw Re-Greasing



If your actuator has a preloaded roller screw, do not remove it from the cylinder. Preloaded screws require special tooling and procedures for proper disassembly and reassembly. Contact Exlar Corporation to arrange for maintenance of a preloaded screw actuator.

Disassembly

Refer to the exploded view on the following page.

1. Remove the actuator assembly from the machine by disconnecting the cables, main rod coupling and actuator mounting bolts or fasteners.
2. If your unit does not have an external anti rotate assembly, skip this step. Loosen the two machine screws that clamp the anti-rotate cross member to the actuator output rod. Slide the anti-rotate mechanism forward and off the actuator.



The end cap houses the Tritex drive and control. Extreme care should be taken when removing the tie rod nuts or tie rods so as not to twist or pull on the drive section of the actuator. Do not disconnect the wiring between the drive and the actuator.

- 3 Remove the screws holding the seal gland to the face plate. With the screws removed, pull the seal gland off. Pry spots are located on each side of the gland to aid in removal.
- 4 When the seal gland is removed, the open end of the roller screw internally threaded cylinder (ITC) is visible. The roller screw can be removed by turning it counter clockwise and threading it out of the cylinder. It may be necessary to keep the roller screw cylinder from turning to remove the screw.

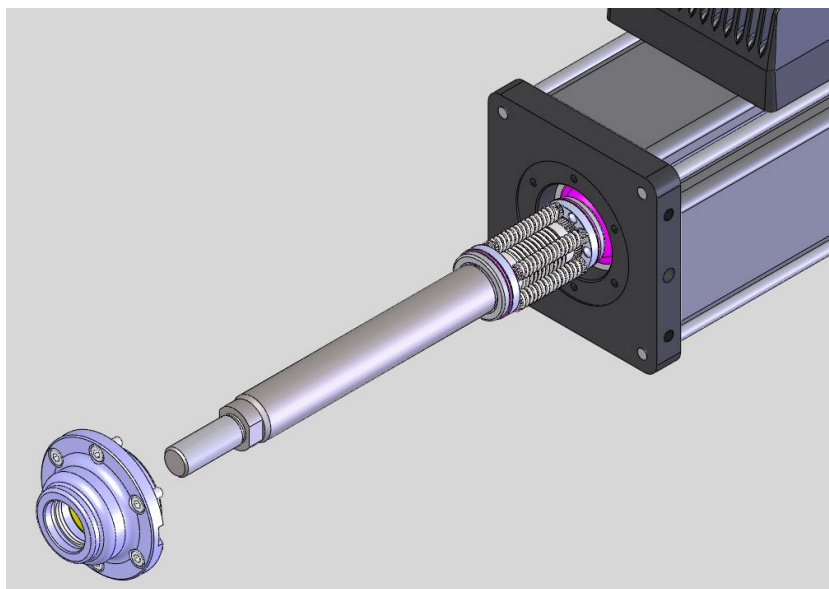

Lubrication Maintenance

Grease lubricated units will require periodic inspection and renewal of the roller screw grease. The table below shows the recommended grease renewal period.

RMS rotational speed (RPM)	Recommended Grease Renewal Period (hours)	
	CASE TEMP 65°C (149°F)	CASE TEMP 80°C (176°F)
250	10,000	5,000
500	8,500	4,250
1000	6,000	3,000
1500+	3,500	1,750

Grease Renewal

The angular contact thrust bearings located in the front of the actuator, the roller screw cylinder, and the roller screw assembly are the components that require grease. They require a coating of grease. They do not need to be packed with grease. Excess grease requires more torque from the motor when returned to operation, and does not improve the lubrication of the unit.

1. Use a brush to work approximately 0.5 in³ of grease for every 3 inches of stroke length into the roller screw cylinder. Be sure to cover all of the threaded areas of the cylinder.
2. Use a brush to work grease in to the roller screw assembly. Be sure to cover all the threaded surfaces of the screw assembly. This can be accomplished by applying grease to a few places on the roller screw assembly and rotating the components repeatedly in both directions to work the grease into the assembly.

Reassembly

1. Rethread the roller screw into the internally threaded cylinder (ITC). It is a multiple start screw, and this is not always easy. **DO NOT FORCE THE ROLLER SCREW INTO THE CYLINDER.** It is best to have the actuator vertical with the open end of the roller screw cylinder facing up. Position the roller screw above the cylinder so that it is aligned axially with the ITC. Slowly turn the roller screw 1/4 to 1/2 a turn counterclockwise with it in contact with the ITC. This will help to align the threads on the roller screw with the threads in the ITC. Rotate the roller screw clockwise and it should begin to thread into the cylinder. If it does not turn freely, remove it and begin again. When threading the screw into the cylinder, it will roll freely into the actuator. When it reaches the portion of the cylinder that contains the motor magnets, the roller screw will be more difficult to turn because of the magnetic field of the magnets. **THIS IS NORMAL.** Continue to thread the roller screw into the cylinder. When it reaches the bottom, it will become difficult to turn and the motor and bearings will begin to rotate with it. The roller screw is now fully inserted into the cylinder.
2. Place a small amount of seal lubricant on the inside surface of the seal/bushing assembly.
3. Carefully slide the bushing/seal assembly over the actuator rod end. The seal is a tight fit on the rod end. Take care not to damage the seal on the threads of the extending rod. Standard T2M Series rods have a chamfer to provide a lead in for replacement of the seal and bushing. The mounting screws should have a low or medium strength thread locker added, such as Loctite 222MS. The mounting screws torque values are as follows.

Tritex 75 mm: 10 in-lbs (0.83 lbf-ft, 1.13 N-m)

4. If your actuator has an external anti-rotate mechanism, slide the rod or rods of the anti-rotate mechanism through the front flange and into the guide bushing or bushings mounted to the rear of the flange. Position the extending rod so that the wrench flats are parallel to the long side of the flange. Slide the cross member assembly of the anti-rotate mechanism over the end of the rod and onto the wrench flats. Tighten the two screws that clamp the assembly to the actuator rod.

Maintenance Procedures for Complete Re-Greasing

Disassembly

Refer to the exploded view on the following page.

1. Remove the actuator assembly from the machine by disconnecting the cables, main rod coupling and actuator mounting bolts or fasteners.
2. If your unit does not have an external anti rotate assembly, skip this step. Loosen the two machine screws that clamp the anti-rotate cross member to the actuator output rod. Slide the anti-rotate mechanism forward and off the actuator.
3. Remove the rear tie rod nuts from the back of the actuator.



The end cap houses the Tritex drive and control. Extreme care should be taken when removing the tie rod nuts or tie rods so as not to twist or pull on the drive section of the actuator. Do not disconnect the wiring between the drive and the actuator.

4. If your actuator does not have a front flange, skip this step. Slide the front flange forward and off the actuator. The tie rods will remain attached to the front flange.
5. When the face plate is removed, the thrust bearing and the open end of the roller screw internally threaded cylinder (ITC) are visible. The roller screw can be removed by turning it counter clockwise and threading it out of the cylinder. It may be necessary to keep the roller screw cylinder from turning to remove the screw.

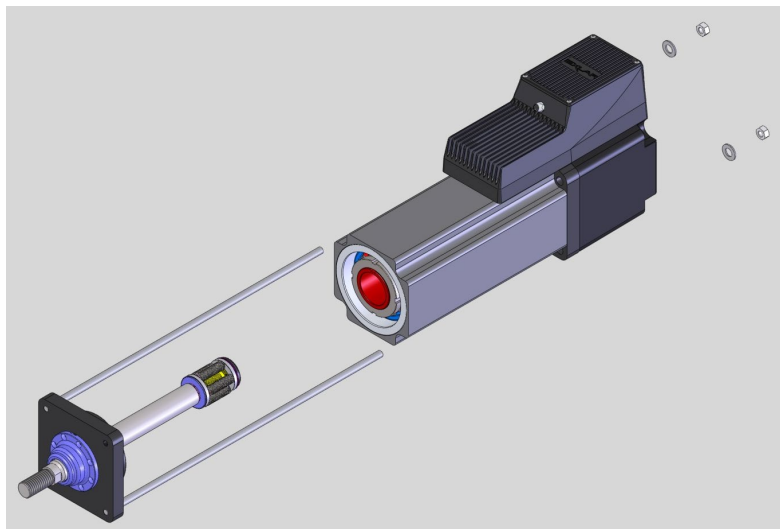

Lubrication Maintenance

Grease lubricated units will require periodic inspection and renewal of the bearing and roller screw grease. The table below shows the recommended grease renewal period.

RMS rotational speed (RPM)	Recommended Grease Renewal Period (hours)	
	CASE TEMP 65°C (149°F)	CASE TEMP 80°C (176°F)
250	10,000	5,000
500	8,500	4,250
1000	6,000	3,000
1500+	3,500	1,750

Grease Renewal

The angular contact thrust bearings located in the front of the actuator, the roller screw cylinder, and the roller screw assembly are the components that require grease. They require a coating of grease. They do not need to be packed with grease. Excess grease requires more torque from the motor when returned to operation, and does not improve the lubrication of the unit.

1. Use a brush to work approximately 0.5 in³ of grease for every 3 inches of stroke length into the roller screw cylinder. Be sure to cover all of the threaded areas of the cylinder.

2. Use a brush to work grease in to the roller screw assembly. Be sure to cover all the threaded surfaces of the screw assembly. This can be accomplished by applying grease to a few places on the roller screw assembly and rotating the components repeatedly in both directions to work the grease into the assembly.
3. Force grease into the front of the thrust bearing assembly. Make a concerted effort to insure that the grease is well worked in. Grease must reach the bearing just behind the bearing that is visible as well. Use the following amounts of grease for each size roller screw and bearing:

Tritex 60: 0.5 in³

Tritex 75 & 90: 0.75 in³

Tritex 115: 1.0 in³

Reassembly

1. Rethread the roller screw into the internally threaded cylinder (ITC). It is a multiple start screw, and this is not always easy. **DO NOT FORCE THE ROLLER SCREW INTO THE CYLINDER.** It is best to have the actuator vertical with the open end of the roller screw cylinder facing up. Position the roller screw above the cylinder so that it is aligned axially with the ITC. Slowly turn the roller screw 1/4 to 1/2 a turn counterclockwise with it in contact with the ITC. This will help to align the threads on the roller screw with the threads in the ITC. Rotate the roller screw clockwise and it should begin to thread into the cylinder. If it does not turn freely, remove it and begin again. When threading the screw into the cylinder, it will roll freely into the actuator. When it reaches the portion of the cylinder that contains the motor magnets, the roller screw will be more difficult to turn because of the magnetic field of the magnets. **THIS IS NORMAL.** Continue to thread the roller screw into the cylinder. When it reaches the bottom, it will become difficult to turn and the motor and bearings will begin to rotate with it. The roller screw is now fully inserted into the cylinder.
2. Place a small amount of seal lubricant on the inside surface of the seal/bushing assembly.

3. Carefully slide the face plate and bushing/seal assembly over the actuator rod end, while guiding the tie rods through the holes in the rear end cap of the actuator. The seal is a tight fit on the rod end. Take care not to damage the seal on the threads of the extending rod. Standard Tritex rods have a chamfer to provide a lead in for replacement of the seal and bushing. Be sure that the faceplate seats completely and squarely on the front of the actuator. The inner surface of the faceplate provides the pre-loading for the bearings, and it is important that it is properly seated.

Units with a Front Flange

Replace the faceplate as described above. Remount front flange by sliding tie rods through the holes in the faceplate and through the holes in the rear end cap. Pilot the flange on the pilot diameter located on the front of the faceplate.

4. Replace the rear tie rod washers and nuts and tighten to the proper torque. Tighten the nuts simultaneously by partially tightening each in an opposing corner pattern until each is torqued to the rated value as follows.

Tritex 75: 90 lbf-in (7.5 lbf-ft, 10.16 N-m)

5. If your actuator has an external anti-rotate mechanism, slide the rod or rods of the anti-rotate mechanism through the front flange and into the guide bushing or bushings mounted to the rear of the flange. Position the extending rod so that the wrench flats are parallel to the long side of the flange. Slide the cross member assembly of the anti-rotate mechanism over the end of the rod and onto the wrench flats. Tighten the two screws that clamp the assembly to the actuator rod.

ACCESSORIES

Cables

TTIOC-xxx I/O Cable

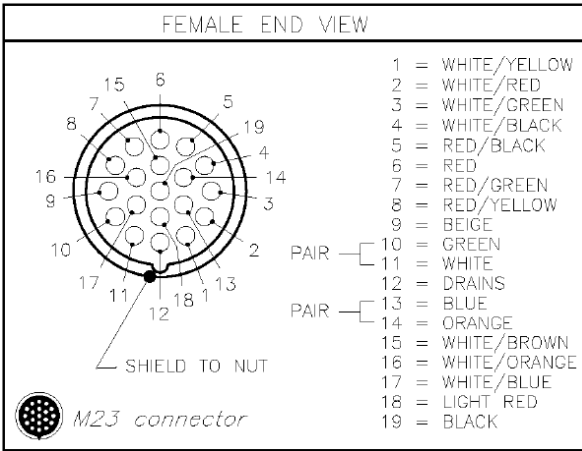
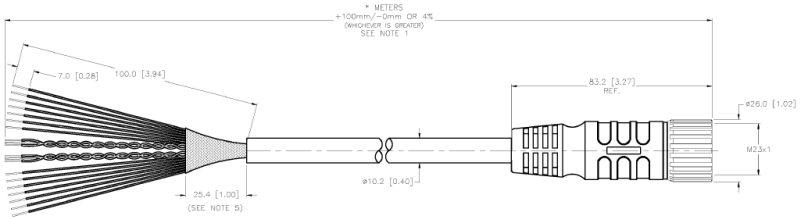

SPECIFICATIONS	
CONTACT CARRIER MATERIAL/COLOR	NYLON or PBT/GRAY
MOLDED HEAD MATERIAL/COLOR	THERMOPLASTIC PUR/BLACK
CONTACT MATERIAL/PLATING	BRASS/GOLD
COUPLING NUT MATERIAL/PLATING	BRASS/NICKEL
RATED CURRENT [A]	3.0 A
RATED VOLTAGE [V]	150 V
OUTER JACKET MATERIAL/COLOR	PVC/BLACK
CONDUCTOR INSULATION MATERIAL	PVC
NUMBER OF CONDUCTORS [AWG]	18x22 AWG/2x22 AWG DRAIN
SHIELD/BRAID	ALUMINUM FOIL SHIELD/T-C BRAID
TEMPERATURE RANGE	-40°C to +105°C (-40°F to +221°F)
PROTECTION CLASS	IEC IP67

T2IPC-xxx Power Cable

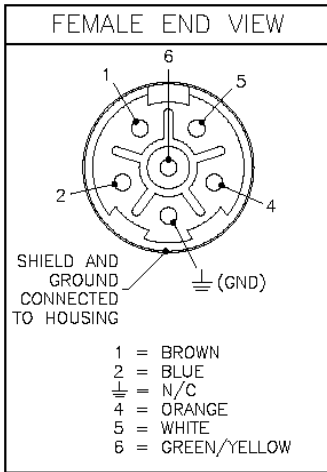

SPECIFICATIONS

CONTACT CARRIER MATERIAL/COLOR	NYLON/GRAY
MOLDED HEAD MATERIAL/COLOR	THERMOPLASTIC PUR/BLACK
CONTACT MATERIAL/PLATING	BRASS/GOLD
COUPLING NUT MATERIAL/PLATING	BRASS/NICKEL
RATED CURRENT [A]	15.0 A
RATED VOLTAGE [V]	300 V
OUTER CABLE JACKET MATERIAL/COLOR	PVC/BLACK
CONDUCTOR INSULATION MATERIAL	PVC
NUMBER OF CONDUCTORS [AWG]	5x14 AWG
DRAIN/SHIELD	16 AWG/ALUM.-POLYESTER FOL & T-C BRAIDED
TEMPERATURE RANGE	-40°C to +105°C (-40°F to +221°F)
PROTECTION CLASS	MEETS IEC IP67

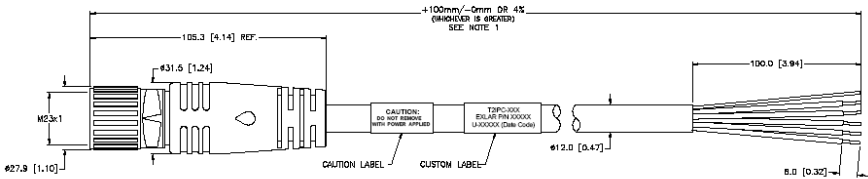

TTICO-xxx Communications Cable

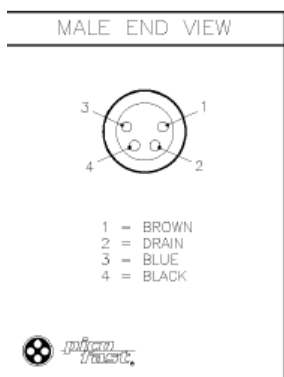
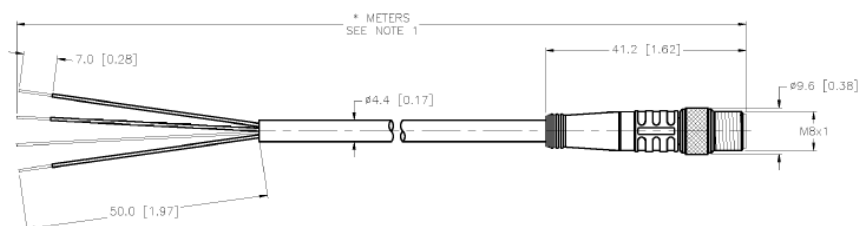

SPECIFICATIONS	
CONTACT CARRIER MATERIAL/COLOR	NYLON OR PUR/BLACK
MOLDED HEAD MATERIAL/COLOR	THERMOPLASTIC PUR/YELLOW
CONTACT MATERIAL/PLATING	BRASS/GOLD
COUPLING NUT MATERIAL/PLATING	BRASS/NICKEL
RATED CURRENT [A]	2.0 A
RATED VOLTAGE [V]	125 VAC/VDC
OUTER JACKET MATERIAL/COLOR	PUR/BLACK
CONDUCTOR INSULATION MATERIAL	PVC
NUMBER OF CONDUCTORS [AWG]	3x24 AWG
DRAIN/SHIELD	26 AWG DRAIN/FOIL
TEMPERATURE RANGE	-40°C to +105°C (-40°F to +221°F)
PROTECTION CLASS	MEETS NEMA 1,3,4,6P AND IEC IP67

Communication Converter

When connecting the Tritex RS485 port to PC, a communication converter will typically be required.

Exlar offers a USB to RS485 converter with an M8 connector ready to connect to the Tritex port. Model # CBL-T2USB485-M8-xxx. This converter is not isolated and is not recommended for permanent installation.

Caution: If another master is on the network such as PLC or HMI, this converter must be removed from the RS485 end. Leaving it connected with the USB end unconnected will load down the RS485 network and not allow it to function.

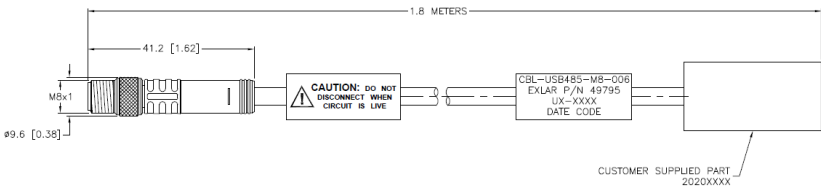

Braking Resistor T2BR1

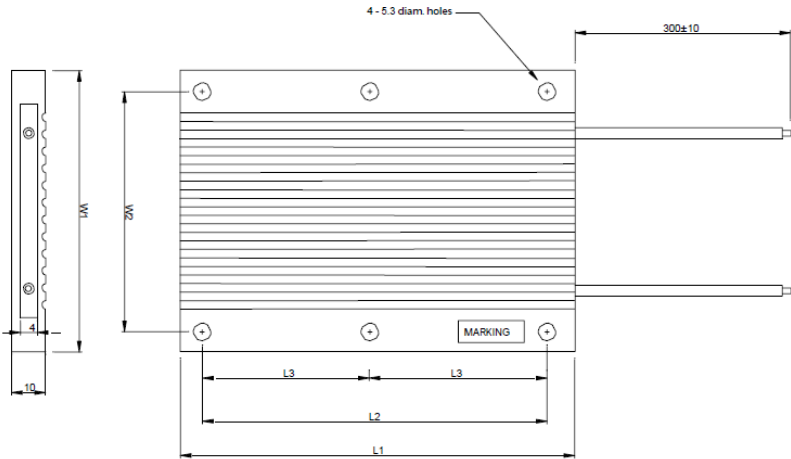

Dimensions

Model	Dimensions [mm]				Weight [g]
	L1 ±1	L2 ±0.3	W1 ±0.3	W2 ±0.3	
ULN50	70	50	60	50	100
ULN100	120	100	60	50	160 ←

RETURNING A PRODUCT FOR REPAIR

STANDARD EVALUATION AND REPAIR LEADTIME:

- Leadtime is dependent upon production capacity and level of demand. Please contact the factory for current leadtime.

EXPEDITED EVALUATION LEADTIME:

- An additional charge per unit can be quoted to expedite an evaluation.
- Ability to expedite is dependent upon production capacity and level of demand. Please contact the factory for current expedited evaluation lead time.

PROCEDURE:

- Please discuss the return with Exlar Technical Support prior to requesting an RGA number to see if it is possible to resolve the issue prior to return.
- If it is determined that an RGA number is required, please do so by completing an online RGA request form located at <http://exlar.com/return-authorization-request/>
 - International Repairs: Closely follow instructions provided by the Exlar Returned Goods Administrator. Failure to comply with issued instructions may result in delays for repair and return.
- Exlar requires a purchase order at the time of RGA; \$750 on warranty returns (refunded if warranty status is confirmed by the factory), or for the desired service package charge per unit on all non-warranty units.